

*High Accuracy Current Sensor with Pin-Selectable Gains and Adjustable
Overcurrent Fault Detection*

**High Accuracy Current Sensor with
Dual Fault Detection and Adjustable Gain**

Description

SC824/SC825 fully integrated current sensor series is an integrated current sensor with wide isolation distance and high current capability developed by SENK SEMI. This product adopts a wide-body SOP-16 package, and achieves a current lead impedance as low as $0.8\text{m}\Omega$ on a $10.3\text{mm}\times 10.4\text{mm}\times 2.3\text{mm}$ package, making it suitable for power systems requiring measurement up to 130A.

This product is a high-precision current sensor based on the Hall Effect, that adopts its own patented digital temperature compensation technology, differential sensing technology, and isolation packaging technology, which can ensure accurate sensing acquisition accuracy and very stable performance indicators in complex industrial environments

One of the advantages of the SC824/5 series is that provides adjustable gain levels, which can be easily configured by external circuit adjustment through the two logic pins of the GAIN_SEL, which can be designed to meet the application of the same model in different models, increasing design flexibility.

Another advantage of this series is that it is designed with fast and slow fault monitoring functions for open-drain outputs, which are ideal for severe short-circuit fault detection and light current overload detection, respectively, where the slow fault function allows the user to create a resistor divider from the power supply to adjust the fault threshold, which is flexible in fault detection and greatly simplifies the board application layout.

SENK SEMI is committed to core chip technology to bring customers the best current sensing solutions.

High Accuracy Current Sensor with Pin-Selectable Gains and Adjustable Overcurrent Fault Detection

Features

- Isolated measurement, isolated voltage up to 4.8kv @50HZ,1min
- Can measure DC, AC current
- Signal detection bandwidth up to 240khz
- Lowest current wire impedance:0.8mΩ
- 13kA 8/20us inrush current capability
- Viout – Vref differential output mode is supported
- Support 3.3/5V power supply
- It has two logic pins that allow the user to select the gain level for external circuitry
- Differential sensing technology has high anti-interference ability to the external environment
- User configurable fault detection function
- FLAG_F: Fast protection, suitable for severe short circuit detection
- FLAG_S: Slow protection for overload detection and user configuration
- The built-in fixed reference that is not affected by fluctuations in the supply voltage
- Static voltage output support: 0.1VCC/0.5VCC、fixed2.5V、fixed1.5V、fixed1.65V
- Response time as low as 1.8uS
- Wide range of measured current: 0A~130A
- High accuracy: Accuracy error < 1% at 25°C
Operating temperature: Accuracy error <2%
- Strong driving capability, supporting output ports with loads as low as 2kΩ
- Independent intellectual property rights
- Isolation safety certification:



Package

◆ Top View
(mark information is only for illustrative purposes)

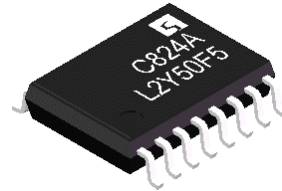

Current Path view:



Typical Application

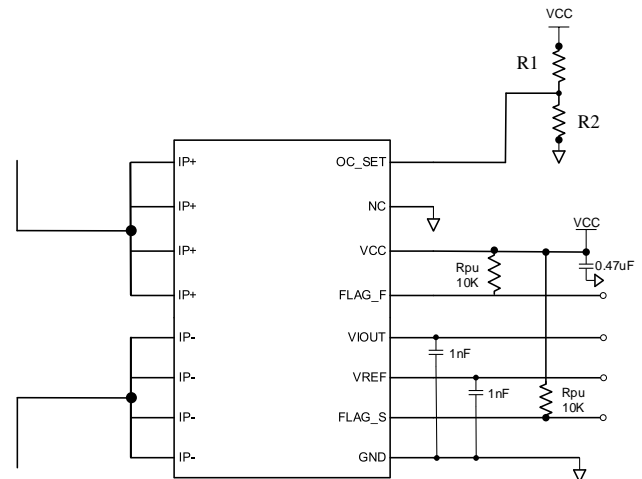

High Accuracy Current Sensor with Pin-Selectable Gains and Adjustable Overcurrent Fault Detection

Order information

Part Number	Charac- teristics code	Temp Range	Packing	Current IP Range (A) *3	0A Output (V) *1	Sensitivity*2 (mV/A)	Power Supply (V)	Overcurrent Detection	Gain Adjustment			
SC824AFT-25F5	A	F(-40~125°C)	T (Reel, 1500 pieces/reel)	± 25	F(2.5)	80	5	Y	N			
SC824AFT-50F5				± 50	F(2.5)	40	5	Y	N			
SC825AFT-79F3				± 79	F(1.65)	16.67	3.3	Y	N			
SC824BFT-15G5	B	F(-40~125°C)	T (Reel, 1500 pieces/reel)	± 15	G(1.5)	90	5	Y	N			
SC824BFT-35G5				± 35	G(1.5)	38.5	5	Y	N			
SC824BFT-65G5				± 65	G(1.5)	20.5	5	Y	N			
SC825BFT-105F3				± 105	F(1.65)	12.5	3.3	Y	N			
SC824CGT-50F5	C	G(-40~150°C)	T (Reel, 1500 pieces/reel)	±12.5/±25/±50	F(2.5)	160/80/40	5	Y	Y			
SC824CGT-66F5				±16.66/ ±33.33/± 66.7	F(2.5)	120/60/30	5	Y	Y			
SC824CGT-75F5				±18.7/±37.5/±75	F(2.5)	106.6/53.33/26.66	5	Y	Y			
SC824CGT-80F5				±10/±20/±40/±80	F(2.5)	200/100/50/25	5	Y	Y			
SC824CGT-133F5				±33/ ±66 /± 133	F(2.5)	60/30/15	5	Y	Y			
SC825CGT-30F3				±7.5/ ±15/± 30	F(1.65)	176/88/44	3.3	Y	Y			
SC825CGT-40F3				±10/±20/±40	F(1.65)	132/66/33	3.3	Y	Y			
SC825CGT-65F3				±16.2/±32.5/±65	F(1.65)	81.23/40.61/20.31	3.3	Y	Y			
SC825CGT-65U3				+16.25/+32.5/+65	U(1.65)	162.44/81.22/40.61	3.3	Y	Y			
SC824DFT-10F5	D	F(-40~125°C)	T (Reel, 1500 pieces/reel)	± 10	F(2.5)	200	5	Y	N			
SC824DFT-20F5				± 20	F(2.5)	100	5	Y	N			
SC824DFT-25F5				± 25	F(2.5)	80	5	Y	N			
SC824DFT-30F5				± 30	F(2.5)	66	5	Y	N			
SC824DFT-40F5				± 40	F(2.5)	50	5	Y	N			
SC824DFT-50F5				± 50	F(2.5)	40	5	Y	N			
SC824DFT-65F5				± 65	F(2.5)	30.75	5	Y	N			
SC824DFT-75F5				± 75	F(2.5)	26.66	5	Y	N			
SC824DFT-80F5				± 80	F(2.5)	25	5	Y	N			
SC824DFT-100F5				± 100	F(2.5)	20	5	Y	N			
SC824DFT-25U5				+ 25	U(0.1VCC)	160	5	Y	N			
SC824DFT-30U5				+ 30	U(0.1VCC)	132	5	Y	N			
SC825DFT-10F3				± 10	F(1.65)	132	3.3	Y	N			
SC825DFT-20F3				± 20	F(1.65)	66	3.3	Y	N			
SC825DFT-25F3				± 25	F(1.65)	52.8	3.3	Y	N			
SC825DFT-30F3				± 30	F(1.65)	44	3.3	Y	N			
SC825DFT-50F3				± 50	F(1.65)	26.4	3.3	Y	N			
SC825DFT-65F3				± 65	F(1.65)	20.31	3.3	Y	N			
SC825DFT-80F3				± 80	F(1.65)	16.5	3.3	Y	N			
SC825DFT-100F3				± 100	F(1.65)	13.2	3.3	Y	N			
SC825DFT-65U3				± 65	U(0.1VCC)	40.61	3.3	Y	N			
SC824EFT-30F5				E	F(-40~125°C)	T (Reel, 1500 pieces/reel)	±30	F(2.5)	66	5	Y	N
SC824EFT-40F5							± 40	F(2.5)	50	5	Y	N
SC824EFT-65F5							± 65	F(2.5)	30.75	5	Y	N
SC824EFT-75F5							± 75	F(2.5)	26.6	5	Y	N
SC825EFT-20F3							± 20	F(1.65)	66	3.3	Y	N
SC825EFT-40F3							± 40	F(1.65)	33	3.3	Y	N

High Accuracy Current Sensor with Pin-Selectable Gains and Adjustable Overcurrent Fault Detection

SC825EFT-65F3				± 65	F(1.65)	20	3.3	Y	N
SC825EFT-75F3				± 75	F(1.65)	17.6	3.3	Y	N
SC825EFT-30U3				+30	U(0.1VCC)	88	3.3	Y	N

Note1: Type F,B,U,G Reference output types when IP=0A, F is recommended by default

F	When IP has no current, VIOUT@0A=VREF=2.5V or 1.65V, suitable for bidirectional current detection, zero point and sensitivity do not change with VCC ratio
G	When IP has no current, VIOUT@0A=VREF=1.5V, suitable for bidirectional current detection, zero point and sensitivity do not change with VCC ratio
B	When IP has no current, VIOUT@0A=VREF=0.5VCC, suitable for bidirectional current detection, zero point and sensitivity change with VCC ratio
U*2	When IP has no current, VIOUT@0A=VREF=0.1VCC, suitable for unidirectional current detection, zero point and sensitivity change with VCC ratio

Note2: In U-mode, the dynamic range is x2, so the sensitivity is x2; If customers have different sensitivity or zero setting needs, they can request our FAE/ agent

Note3: Factory shipment default Mask=0uS, this function is turned off, if the customer needs to turn on the function, you can ask our FAE

Pin Configuration(Top view)

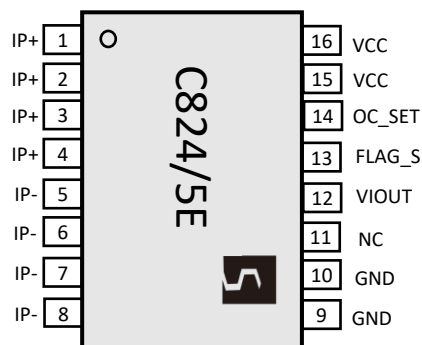
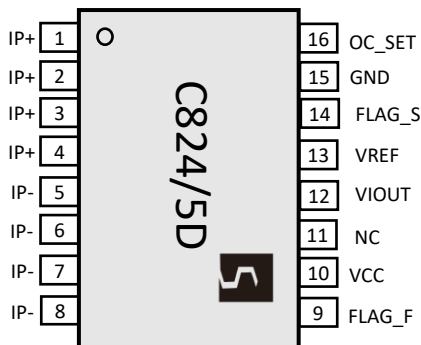
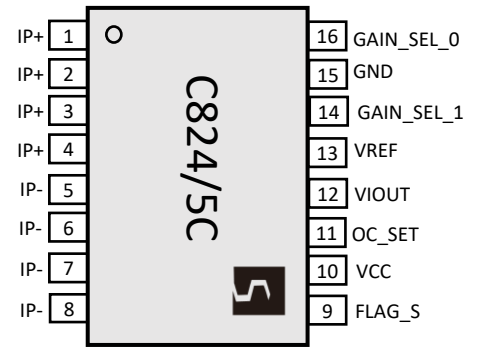
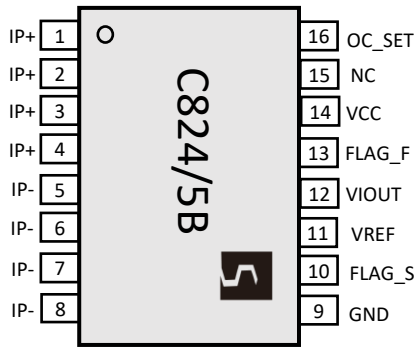
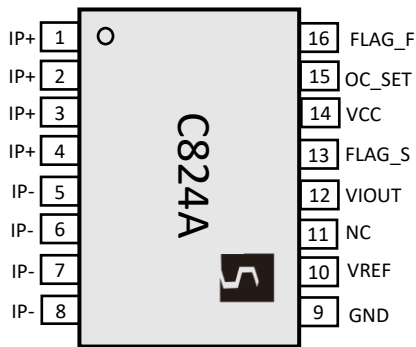

High Accuracy Current Sensor with Pin-Selectable Gains and Adjustable Overcurrent Fault Detection

824A Pin number	824B Pin number	824C Pin number	824D Pin number	824/5E Pin number	Pin Name	Description
1/2/3/4	1/2/3/4	1/2/3/4	1/2/3/4	1/2/3/4	IP+	Terminals for current being sampled; fused internally, support connect to 1/2/3/4
5/6/7/8	5/6/7/8	5/6/7/8	5/6/7/8	5/6/7/8	IP-	Terminals for current being sampled; fused internally, support connect to 5/6/7/8
9	9	15	15	9/10	GND	Signal Ground terminal
12	12	12	12	12	VIOUT	Analog output signal, $VIOUT=IP*Sens+Vref$
14	14	10	10	15/16	VCC	Device power supply terminal
10	11	13	13	/	VREF	Reference terminal, supporting input and output. Specifically define Note 1 of the above ordering information $VIOUT=Vref (IP=0A)$
15	16	11	16	14	OC_SET	External fault threshold voltage (support NC)
16	13	/	9	/	FLAG_F	Fast fault output, built-in overcurrent threshold multiple
13	10	9	14	13	FLAG_S	Slow fault output
11	15	/	11	11	NC	No connection
/	/	16	/	/	GAIN_SEL_0	Gain selection bit0
/	/	14	/	/	GAIN_SEL_1	Gain selection bit1

Thermal Rise vs. Primary Current

Note1: At 26°C, the relationship between the junction temperature of the package and the primary side current of the whole series of SC824/5 is tested based on DEMO board.

Note2: The PCB is 2oz copper thickness, and the copper pour area is 350 mm² for the temperature rise test, and each current point lasts for at least 20min until the temperature point reaches a constant record junction temperature, in order to give a more meaningful reference close to the user's actual working conditions.

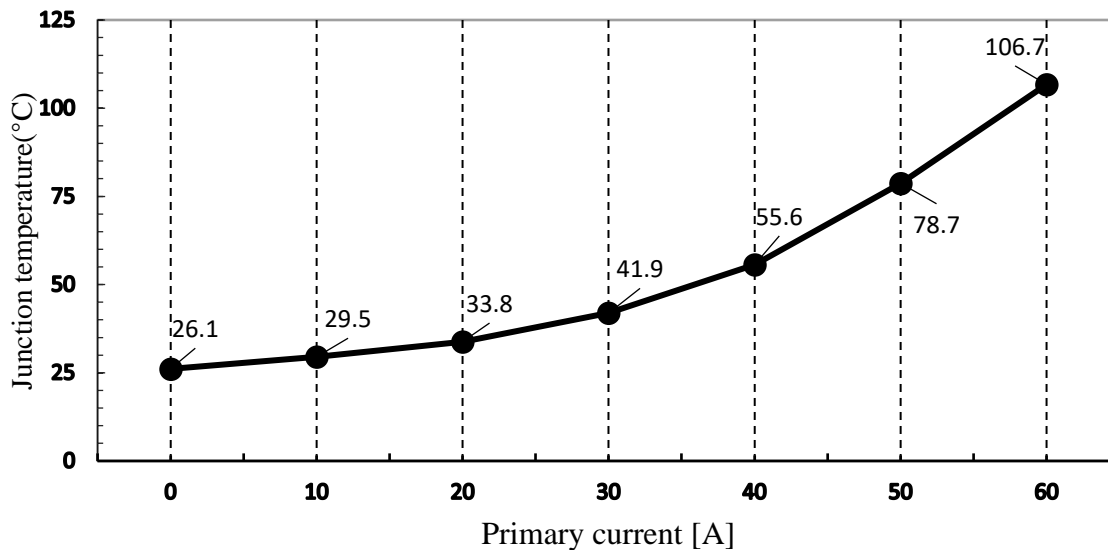

High Accuracy Current Sensor with Pin-Selectable Gains and Adjustable Overcurrent Fault Detection

Demo Board information

	DEMO1	Units
PCB Layer Number	2	
PCB Copper layer thickness	2	Oz
Total Copper size connected to Primary pins(including all layers)	350	mm ²
PCB Board Thickness	1.6	mm

Functional Block Diagram

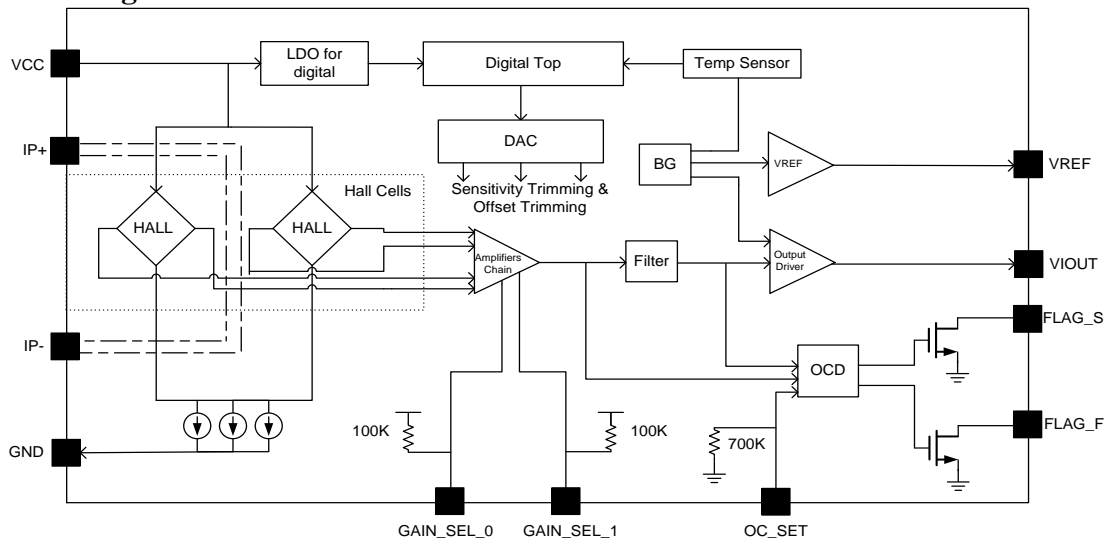

High Accuracy Current Sensor with Pin-Selectable Gains and Adjustable Overcurrent Fault Detection

Absolute Maximum Ratings

Absolute maximum rating is the operating limit of a device, exceeding which may cause device damage. Frequent operation outside this value range may affect device reliability.

Symbol	Characteristic	Notes	Ratings	Units
V _{CC}	Supply voltage		6	V
V _{RCC}	Reverse Supply Voltage		-0.1	V
V _{IOUT}	Output Voltage		6	V
V _{RIOUT}	Reverse Output Voltage	V _{IOUT} , V _{REF}	-0.1	V
V _{OI}	Forward Output Voltage	applicable to the FLAG overflow function	6	V
V _{RI}	Reverse Output Voltage		-0.1	V
V _{FLAG}	Forward Output Voltage	applicable to the OC_SET function	6	V
V _{RFLAG}	Reverse Output Voltage		-0.1	V
V _{OC_SET}	Operating Temperature	Range G	6	V
V _{ROC_SET}	反向输入电压	Range F	-0.1	V
T _A	环境温度范围 Maximum Junction Temperature Storage Temperature	Range E	-40~150	°C
			-40~125	
			-40~85	
T _{J(max)}	Output Current Source	Shorted Output-to-Ground Current	165	°C
T _{stg}	Output Current Sink	Shorted Output-to-VCC Current	-65~170	°C
I _{OUT(Source)}	V _{ref} Current Source	Shorted V _{ref} -to-Ground Current	30	mA
I _{OUT(Sink)}	V _{ref} Current Sink	Shorted V _{ref} -to-VCC Current	30	mA
I _{REF(Source)}	Maximum Continuing IP Current	Based on SENK's Demo Test Board	15	mA
I _{REF(Sink)}	Transient Over Current at Ambient Temperature	Based on SENK's Demo Test Board , 1pulse , 100ms , 1% Duty Cycle	15	mA
I _{Pmax}	HBM mode		65	A
I _{Pover}	Supply voltage		300	A
ESD	Reverse Supply Voltage		4	kV

Isolation Characteristics

Symbol	Characteristic	Notes	Ratings	Units
V _{ISO}	RMS voltage for AC insulation test,50Hz,1min	Agency type-tested for 60 seconds per UL60950-1	4800	V _{rms}
V _{WVRI}	Working Voltage for Basic Isolation	Maximum working voltage according to UL60950-1	1550	V _{Peak}
D _{cl}	Clearance	Minimum distance through air from IP leads to signal leads	8	mm
D _{cr}	Creepage distance	Minimum distance along package body from IP leads to signal leads	8	mm
CTI	Comparative trackong index	the electrical breakdown (tracking) properties of an insulating material	600	V
V _{IOSM}	Maximum surge isolation voltage	Tested ±5 pulses at 2/minute in compliance to IEC 61000-4-5 1.2 μs (rise) / 50 μs (width).	10	kV
I _{IOSM}	Maximum Transient impulse current	Tested ±5 pulses at 3/minute with 8 μs (rise) / 20 μs (width) to IEC 61000-4-5	13	kA

Note 1: Meet the safety certification of UL60950-1 and CB62368-1

High Accuracy Current Sensor with Pin-Selectable Gains and Adjustable Overcurrent Fault Detection

Reference application Specification

Symbol	Description	Min	Typ	Max	Unit
C _{VCC}	The filter capacitor of power supply is connected between VCC and GND	0.1	0.47		uF
C _{VIOUT}	The filter capacitor of Output is connected between Vout and GND		1		nF
C _{VREF}	The filter capacitor of Output is connected between Vref and GND		1		nF
R _{FLAG_F} /R _{FLAG_S}	The pull-up resistance is connected between FLAG_F and VCC		10		kΩ

Common Electrical Characteristics

Note: Over full range of T_A=25°C, C_{Bypass}=0.47uF, C_{Load}=1nF, V_{CC}=3.3V/5V, sensitivity=40mv/A

Characteristic	Symbol	Test Conditions	Min	Typ	Max	Unit
Supply Voltage	V _{CC}	Operating, SC824XXX-XXX5	4.5	5.0	5.5	V
		Operating, SC825XXX-XXX3	3	3.3	3.6	V
Supply Current	I _{CC}	V _{CC} = 4.5~5.5V, output open		21		mA
		V _{CC} = 3~3.6V, output open		15		mA
Output Resistive Load	R _L	VIOUT 与 GND间	2			kΩ
VREF Resistive Load	R _{LREF}	VREF 与 GND间	2			kΩ
Hall Coupling Factors	CF	T _A = 25°C		2.77		G/A
Anti-external magnetic interference suppression ratio	CMFR	The external interference magnetic field perpendicular to the chip surface		-40.8		dB
Primary Conductor Resistance	R _{PRIMARY}	T _A = 25°C		0.8		mΩ
Temperature Coefficient of Primary Conductor Resistance	TC _R	T _A =-40~125°C		3425		ppm/°C
Hysteresis Voltage	V _{hys}	Viout(IP to +40A then return to 0A)-Viout(IP to -40A,then return to0A)		1		mV
Rise time	t _r	IP=50A		2.08		uS
Propagation Delay	t _{pd}	IP=50A		1.15		uS
Response Time	t _{RESPONSE}	IP=50A		1.82	2	μS
Bandwidth	f	Small-signal -3 dB,		240		kHz
Noise	I _N	BW=240KHz		38.7		mA(rms)
		BW=10KHz		6		mA(rms)
		BW=1KHz		2		mA(rms)
Nonlinearity	E _{LIN}	-50A<IP<50A			1	%
Bidirectional Quiescent Output (suitable for product with suffix B5)	S _{coef_B5}	The zero point is in VCC-related reference voltage mode ,VCC=5.0V, S _{coef} =Sens (VCC)/Sens(5V)		VCC/5		
Bidirectional Quiescent Output (suitable for product with suffix B3)	S _{coef_B3}	The zero point is in VCC-related reference voltage mode ,VCC=3.3V, S _{coef} =Sens (VCC)/Sens (3.3V)		VCC/3.3		
Sensitivity Scale Factor at Fixed Zero Voltage (suitable for F5 Suffix Products)	S _{coef_F5}	VCC=5.0V, The selection is: xxF5 S _{coef} =Sens (VCC)/Sens (5V)		100%		
Sensitivity Scale Factor at Fixed Zero Voltage (suitable for F3 Suffix Products)	S _{coef_F3}	VCC=3.3V, The selection is: xxF3 S _{coef} =Sens (VCC)/Sens (3.3V)		100%		
Supported peripheral inputs Zero voltage dynamic range		VCC=5.0V, The selection is: xxI5	0.5		2.5	V
		VCC=3.3V, The selection is: xxI3	0.33		1.65	V
VIOUT Linear Rail to Rail Output Range	V _{rail-rail}	R _L =4.7kΩ	10		90	%VCC
Power-On Time	t _{PO}	Output reaches steady state level, T _J = 25°C		150		μS
Zero-point power supply rejection ratio	PSRR _Q	Available for F5 and F3 suffix products		-21		dB
Sensitivity power supply rejection ratio	PSRR _S	Available for F5 and F3 suffix products		-13		dB

High Accuracy Current Sensor with Pin-Selectable Gains and Adjustable Overcurrent Fault Detection

FLAG overcurrent detection of electrical parameters

Note1: Over full range of TA=25°C, C_{Bypass}=0.47uF, C_{Load}=1.0nF, R_{pu}=10kΩ, V_{CC}=3.3/5V

Note 2: Whether FLAG_S or FLAG_F sets the trigger threshold current, it is recommended that the actual loaded effective current is 1.15*I_{FLAG}

Characteristic	Symbol	Test Conditions	Min	Typ	Max	Unit
Overcurrent detection of electrical parameters						
OC_SET external input range	V _{OC_SET}	OC_SET input voltage	0		V _{cc}	V
OC_SET PIN input current	I _{IN}	High impedance, pin input current			8	uA
Fault output low voltage	V _{FLAG}	R _{PU} =10kΩ	0		0.5	V
FLAG_F fast fault range	I _{FLAG (F)}	Supported built-in multiples (I _{PR} =peak current) , See the corresponding model Settings for details		0.75*I _{PR} ~2 *I _{PR}		A
FLAG_S slow fault range ^[1]	I _{FLAG (S)}	OC_SET ∈ (0.3*V _{cc} , 0.34*V _{cc})		IPR*0.75		A
		OC_SET ∈ (0.41*V _{cc} , 0.45*V _{cc})		IPR*1		A
		OC_SET ∈ (0.55*V _{cc} , 0.59*V _{cc})		IPR*1.25		A
		OC_SET ∈ (0.65*V _{cc} , 0.71*V _{cc})		IPR*1.5		A
		OC_SET ∈ (0.79*V _{cc} , 0.83*V _{cc})		IPR*1.75		A
OC_SET ∈ (0.91*V _{cc} , 0.97*V _{cc})		IPR*2		A		
FLAG_F restore the threshold point ^[2]	I _{RE}	Current drops to I _{RE} until V _{FLAG} returns to high level		50%*I _{FLAG}		A
FLAG_S restore the threshold point ^[2]				50%*I _{FLAG}		A
FLAG_F back difference value	I _{HYS}	I _{HYS} = I _{FLAG} -I _{RE}		50% I _{FLAG}		A
FLAG_S back difference value				50% I _{FLAG}		A
Dynamic response characteristics of overcurrent detection						
fault clearance time	T _{CF}	The time from the IP address falling below I _{FLAG} -I _{HYS} to the time when V _{FLAG} is pulled above V _{FLAG} ; R _{PU} =10 kΩ		3		uS
FLAG output response time ^[3]	T _R	R _{PU} =10kΩ When the current step jumps to I _{FLAG} *1.15, the response time between FLAG < V _{FLAG}		1.5	2	uS
FLAG_F output hold time ^[4]	T _{HOLD (FLAG_F)}	FLAG_F output continues to pull down time		10		uS
Extra duration of current ^[4]	T _{MASK (FLAG_S)}	There must be time to determine the fault and reduce interference and false triggering		3		uS
FLAG_S output hold time ^[4]	T _{HOLD (FLAG_S)}	FLAG_S output continues to pull down time		10		uS

[1] The relationship between the threshold setting of FLAG_S and the overcurrent trigger point is set in STEP mode to prevent false trigger. The overcurrent trigger point is determined by the voltage obtained by OC_SET, not the resistance value, as described in the section "OC_SET Pin Relationship with FLAG_S".

[2] If the absolute value of the IP is higher than I_{FLAG} (S) or I_{FLAG} (F), the internal fault comparator will trip. The IP must be lower than the I_{RE} before the internal fault comparator will reset.

[3] Response time: It is recommended to obtain the response time <1.5uS when the actual loading current is I_{FLAG}*1.15

[4] In order to ignore the false triggering of the interference current pulse in the application, the FLAG_S trigger condition requires that the primary input current should remain 3uS after the Tr time, which can be simply understood as the total duration of the primary current: Tr+T_{MASK}

[4] Factory shipment defaultMask=0uS, The function is disabled

High Accuracy Current Sensor with Pin-Selectable Gains and Adjustable Overcurrent Fault Detection

Gain selection pin Characteristics

Note 1: Unless otherwise noted, the temperature range is $T_A=25^{\circ}\text{C}$, $C_{\text{Bypass}}=0.47\mu\text{F}$, $C_{\text{Load}}=1.0\text{nF}$, $V_{\text{CC}}=5\text{V}$

Note 2: Applicable to SC824CGT series

Parameter	Symbol	Test Conditions	Min	Typ ^[1]	Max	Unit
Built-in gain pin pull-up resistor	$R_{\text{GAIN_SEL_INT}}$			100		$\text{k}\Omega$
Digital high input voltage	V_{IH}		3.75	5		V
Digital low input voltage	V_{IL}			0	0.5	V
Enter the leakage current	V_{IN}				10	μA

SC824AFT-25F5 Individual Performance Characteristics

Note: Over full range of $T_A=-25^{\circ}\text{C}$, $C_{\text{Bypass}}=0.47\mu\text{F}$, $C_{\text{Load}}=1\text{nF}$, $V_{\text{CC}}=5\text{V}$

Parameter	Symbol	Test Conditions	Min	Typ ^[1]	Max	Unit
NOMINAL PERFORMANCE (Regardless of life time drift error)						
Current-Sensing Range	I_{PR}		-25		25	A
$I_{\text{P}}=0\text{A}$, V_{IOUT} output voltage	V_{OQ}	$I_{\text{P}}=0\text{A}$		2.5		V
V_{REF} output voltage	V_{ref}	Independent of the I_{P} input current		2.5		V
Sensitivity	Sens	$-25\text{A}<I_{\text{P}}<25\text{A}$		80		mV/A
Fast flow threshold range	$\text{IFLAG}(I_{\text{F}})$	Built-in overcurrent threshold(Built-in 10)		31.25		A
Low speed overflow threshold range ^[2]	$\text{IFLAG}(I_{\text{S}})$	$\text{Min}=I_{\text{PR}} * 0.75$, $\text{Max}= I_{\text{PR}} * 2$	18.75		50	A
ACCURACY PERFORMANCE						
Sensitivity Error	E_{SENS}	$I_{\text{PR}} = \pm 25\text{A}$, $T_A = 25^{\circ}\text{C}$	-1.5	± 0.5	+1.5	%
		$I_{\text{PR}} = \pm 25\text{A}$, $T_A = 25\sim 125^{\circ}\text{C}$	-2.5	± 2	+2.5	%
		$I_{\text{PR}} = \pm 25\text{A}$, $T_A = -40\sim 25^{\circ}\text{C}$	-2.5	± 2	+2.5	%
Single output zero error	E_{VOQ}	$I_{\text{P}}=0\text{A}$, $T_A = 25^{\circ}\text{C}$	-10	± 5	+10	mV
		$I_{\text{P}}=0\text{A}$, $T_A = 25\sim 125^{\circ}\text{C}$	-20	± 10	+20	mV
		$I_{\text{P}}=0\text{A}$, $T_A = -40\sim 25^{\circ}\text{C}$	-20	± 10	+20	mV
Differential Output zero Error	E_{VOE}	$I_{\text{P}}=0\text{A}$, $T_A = 25^{\circ}\text{C}$	-10	± 5	+10	mV
		$I_{\text{P}}=0\text{A}$, $T_A = 25\sim 125^{\circ}\text{C}$	-15	± 10	+15	mV
		$I_{\text{P}}=0\text{A}$, $T_A = -40\sim 25^{\circ}\text{C}$	-20	± 10	+20	mV
TOTAL OUTPUT ERROR COMPONENTS : $E_{\text{TOT}} = \{[V_{\text{IOUT_ideal}}(I_{\text{PR}}) - V_{\text{IOUT}}(I_{\text{PR}})] / [\text{Sens}_{\text{ideal}} * I_{\text{PR}}]\} * 100\%$						
Total Output Error	E_{TOT}	$I_{\text{PR}} = \pm 25\text{A}$, $T_A=25^{\circ}\text{C}$	-1.5	± 1	+1.5	%
		$I_{\text{PR}} = \pm 25\text{A}$, $T_A=25^{\circ}\text{C}\sim 125^{\circ}\text{C}$	-2.5	± 2	+2.5	%
		$I_{\text{PR}} = \pm 25\text{A}$, $T_A= -40^{\circ}\text{C} \sim 25^{\circ}\text{C}$	-2.5	± 2	+2.5	%
Accuracy of overcurrent fault threshold						
Fast fault output	$E_{\text{IFLAG_F}}$	$T_A=25^{\circ}\text{C}$		± 15		%
		$T_A=-40^{\circ}\text{C}\sim 125^{\circ}\text{C}$		± 25		%
Slow fault output	$E_{\text{IFLAG_S}}$	$I_{\text{PR}} * 2$, $T_A=25^{\circ}\text{C}$		± 15		%
		$I_{\text{PR}} * 2$, $T_A=-40^{\circ}\text{C}\sim 125^{\circ}\text{C}$		± 25		%

[1] The typical value is ± 1 sigma, and 68.27% of products fall within this range; The maximum/minimum value is ± 3 sigma value, and 99.73% of products fall within this range

[2] For details about the relationship between the IFLAG_S overcurrent trigger threshold and OC_SET , see "The Relationship between OC_SET Pins and FLAG_S ".

High Accuracy Current Sensor with Pin-Selectable Gains and Adjustable Overcurrent Fault Detection

SC824AFT-50F5 Individual Performance Characteristics

Note: Over full range of $T_A=25^{\circ}\text{C}$, $C_{\text{Bypass}}=0.47\mu\text{F}$, $C_{\text{Load}}=1\text{nF}$, $V_{\text{CC}}=5\text{V}$

Parameter	Symbol	Test Conditions	Min	Typ ^[1]	Max	单位
NOMINAL PERFORMANCE (Regardless of life time drift error)						
Current-Sensing Range	I_{PR}		-50		50	A
IP=0A, V _{IOUT} output voltage	V_{OQ}	IP=0A		2.5		V
VREF output voltage	V_{ref}	Independent of the IP input current		2.5		V
Sensitivity	S_{ens}	-50A<IP<50A		40		mV/A
Fast flow threshold range	$I_{\text{FLAG}}(I_{\text{F}})$	Built-in overcurrent threshold (Built-in 10)		62.5		A
Low speed overflow threshold range ^[2]	$I_{\text{FLAG}}(I_{\text{S}})$	Min= $I_{\text{PR}} * 0.75$, Max= $I_{\text{PR}} * 2$,	37.5		100	A
ACCURACY PERFORMANCE						
Sensitivity Error	E_{SENS}	$I_{\text{PR}} = \pm 50 \text{ A}, T_A = 25^{\circ}\text{C}$	-1.5	± 0.5	+1.5	%
		$I_{\text{PR}} = \pm 50 \text{ A}, T_A = 25 \sim 125^{\circ}\text{C}$	-2.5	± 2	+2.5	%
		$I_{\text{PR}} = \pm 50 \text{ A}, T_A = -40 \sim 25^{\circ}\text{C}$	-2.5	± 2	+2.5	%
Single output zero error	E_{VOQ}	IP=0A, $T_A = 25^{\circ}\text{C}$	-10	± 5	+10	mV
		IP=0A, $T_A = 25 \sim 125^{\circ}\text{C}$	-20	± 10	+20	mV
		IP=0A, $T_A = -40 \sim 25^{\circ}\text{C}$	-20	± 10	+20	mV
Differential Output zero Error	E_{VOE}	IP=0A, $T_A = 25^{\circ}\text{C}$	-10	± 5	+10	mV
		IP=0A, $T_A = 25 \sim 125^{\circ}\text{C}$	-15	± 10	+15	mV
		IP=0A, $T_A = -40 \sim 25^{\circ}\text{C}$	-20	± 10	+20	mV
TOTAL OUTPUT ERROR COMPONENTS : $E_{\text{TOT}} = \{[V_{\text{IOUT_ideal}}(I_{\text{PR}}) - V_{\text{IOUT}}(I_{\text{PR}})] / [S_{\text{ens_ideal}} * I_{\text{PR}}]\} * 100\%$						
Total Output Error	E_{TOT}	$I_{\text{PR}} = \pm 50 \text{ A}, T_A = 25^{\circ}\text{C}$	-1.5	± 1	+1.5	%
		$I_{\text{PR}} = \pm 50 \text{ A}, T_A = 25^{\circ}\text{C} \sim 125^{\circ}\text{C}$	-2.5	± 2	+2.5	%
		$I_{\text{PR}} = \pm 50 \text{ A}, T_A = -40^{\circ}\text{C} \sim 25^{\circ}\text{C}$	-2.5	± 2	+2.5	%
Accuracy of overcurrent fault threshold						
Fast fault output	$E_{\text{IFLAG_F}}$	$T_A = 25^{\circ}\text{C}$		± 15		%
		$T_A = -40^{\circ}\text{C} \sim 125^{\circ}\text{C}$		± 25		%
Slow fault output	$E_{\text{IFLAG_S}}$	$I_{\text{PR}} * 2, T_A = 25^{\circ}\text{C}$		± 15		%
		$I_{\text{PR}} * 2, T_A = -40^{\circ}\text{C} \sim 125^{\circ}\text{C}$		± 25		%

[1] The typical value is +/-1 sigma, and 68.27% of products fall within this range; The maximum/minimum value is +/-3 sigma value, and 99.73% of products fall within this range

[2] For details about the relationship between the IFLAG_S overcurrent trigger threshold and OC_SET, see "The Relationship between OC_SET Pins and FLAG_S".

High Accuracy Current Sensor with Pin-Selectable Gains and Adjustable Overcurrent Fault Detection

SC824BFT-15G5 Individual Performance Characteristics

Note: Over full range of $T_A=25^{\circ}\text{C}$, $C_{\text{Bypass}}=0.47\mu\text{F}$, $C_{\text{Load}}=1\text{nF}$, $V_{\text{CC}}=5\text{V}$

Parameter	Symbol	Test Conditions	Min	Typ ^[1]	Max	Unit
NOMINAL PERFORMANCE (Regardless of life time drift error)						
Current-Sensing Range	I_{PR}		-15		15	A
$I_{\text{P}}=0\text{A}$, V_{IOUT} output voltage	V_{OQ}	$I_{\text{P}}=0\text{A}$		1.5		V
VREF output voltage	V_{ref}	Independent of the IP input current		1.5		V
Sensitivity	Sens	$-15\text{A} < I_{\text{P}} < 15\text{A}$		90		mV/A
Fast flow threshold range	$\text{IFLAG}(\text{IF})$	Built-in overcurrent threshold (Built-in 11)		44.44		A
Low speed overflow threshold range ^[2]	$\text{IFLAG}(\text{IS})$	$\text{Min}=2/\text{Sens} * 0.75$, $\text{Max}= 2/\text{Sens} * 2$	16.67		44.44	A
ACCURACY PERFORMANCE						
Sensitivity Error	E_{SENS}	$I_{\text{PR}} = \pm 15\text{A}$, $T_A = 25^{\circ}\text{C}$	-1.2	± 0.8	+1.2	%
		$I_{\text{PR}} = \pm 15\text{A}$, $T_A = 25\sim 125^{\circ}\text{C}$	-2	± 1.2	+2	%
		$I_{\text{PR}} = \pm 15\text{A}$, $T_A = -40\sim 25^{\circ}\text{C}$	-2.2	± 1.5	+2.2	%
Single output zero error	E_{VOQ}	$I_{\text{P}}=0\text{A}$, $T_A = 25^{\circ}\text{C}$	-10	± 8	+10	mV
		$I_{\text{P}}=0\text{A}$, $T_A = 25\sim 125^{\circ}\text{C}$	-18	± 10	+18	mV
		$I_{\text{P}}=0\text{A}$, $T_A = -40\sim 25^{\circ}\text{C}$	-20	± 15	+20	mV
Differential Output zero Error	E_{VOE}	$I_{\text{P}}=0\text{A}$, $T_A = 25^{\circ}\text{C}$	-10	± 8	+10	mV
		$I_{\text{P}}=0\text{A}$, $T_A = 25\sim 125^{\circ}\text{C}$	-15	± 8	+15	mV
		$I_{\text{P}}=0\text{A}$, $T_A = -40\sim 25^{\circ}\text{C}$	-18	± 10	+18	mV
TOTAL OUTPUT ERROR COMPONENTS : $E_{\text{TOT}} = \{[V_{\text{IOUT_ideal}}(I_{\text{PR}}) - V_{\text{IOUT}}(I_{\text{PR}})] / [\text{Sens}_{\text{ideal}} * I_{\text{PR}}]\} * 100\%$						
Total Output Error	E_{TOT}	$I_{\text{PR}} = \pm 15\text{A}$, $T_A=25^{\circ}\text{C}$	-1.5	± 1	+1.5	%
		$I_{\text{PR}} = \pm 15\text{A}$, $T_A=25^{\circ}\text{C}\sim 125^{\circ}\text{C}$	-2.2	± 1.5	+2.2	%
		$I_{\text{PR}} = \pm 15\text{A}$, $T_A=-40^{\circ}\text{C}\sim 25^{\circ}\text{C}$	-2.5	± 1.5	+2.5	%
Accuracy of overcurrent fault threshold						
Fast fault output	$E_{\text{IFLAG_F}}$	$T_A=25^{\circ}\text{C}$		± 15		%
		$T_A=-40^{\circ}\text{C}\sim 125^{\circ}\text{C}$		± 25		%
Slow fault output	$E_{\text{IFLAG_S}}$	$\text{Max}=2/\text{Sens} * 2$, $T_A=25^{\circ}\text{C}$		± 15		%
		$\text{Max}=2/\text{Sens} * 2$, $T_A=-40^{\circ}\text{C}\sim 125^{\circ}\text{C}$		± 25		%

[1] The typical value is +/-1 sigma, and 68.27% of products fall within this range; The maximum/minimum value is +/-3 sigma value, and 99.73% of products fall within this range

[2] For details about the relationship between the IFLAG_S overcurrent trigger threshold and OC_SET, see "The Relationship between OC_SET Pins and FLAG_S".

High Accuracy Current Sensor with Pin-Selectable Gains and Adjustable Overcurrent Fault Detection

SC824BFT-35G5 Individual Performance Characteristics

Note: Over full range of $T_A=25^{\circ}\text{C}$, $C_{\text{Bypass}}=0.47\mu\text{F}$, $C_{\text{Load}}=1\text{nF}$, $V_{\text{CC}}=5\text{V}$

Parameter	Symbol	Test Conditions	Min	Typ ^[1]	Max	Unit
NOMINAL PERFORMANCE (Regardless of life time drift error)						
Current-Sensing Range	I_{PR}		-35		35	A
$I_{\text{P}}=0\text{A}$, V_{IOUT} output voltage	V_{OQ}	$I_{\text{P}}=0\text{A}$		1.5		V
VREF output voltage	V_{ref}	Independent of the IP input current		1.5		V
Sensitivity	Sens	$-35\text{A}<I_{\text{P}}<35\text{A}$		38.5		mV/A
Fast flow threshold range	$\text{IFLAG}(I_{\text{F}})$	Built-in overcurrent threshold (Built-in 10)		65		A
Low speed overflow threshold range ^[2]	$\text{IFLAG}(I_{\text{S}})$	$\text{Min}=2/\text{Sens} * 0.75$, $\text{Max}= 2/\text{Sens} * 2$,	38.9		104	A
ACCURACY PERFORMANCE						
Sensitivity Error	E_{SENS}	$I_{\text{PR}} = \pm 35\text{A}$, $T_A = 25^{\circ}\text{C}$	-1.2	± 0.8	+1.2	%
		$I_{\text{PR}} = \pm 35\text{A}$, $T_A = 25\sim 125^{\circ}\text{C}$	-1.8	± 1.2	+1.8	%
		$I_{\text{P}} = \pm 35\text{A}$, $T_A = -40\sim 25^{\circ}\text{C}$	-2	± 1.5	+2	%
Single output zero error	E_{VOQ}	$I_{\text{P}}=0\text{A}$, $T_A = 25^{\circ}\text{C}$	-10	± 8	+10	mV
		$I_{\text{P}}=0\text{A}$, $T_A = 25\sim 125^{\circ}\text{C}$	-12	± 8	+12	mV
		$I_{\text{P}}=0\text{A}$, $T_A = -40\sim 25^{\circ}\text{C}$	-15	± 10	+15	mV
Differential Output zero Error	E_{VOE}	$I_{\text{P}}=0\text{A}$, $T_A = 25^{\circ}\text{C}$	-10	± 8	+10	mV
		$I_{\text{P}}=0\text{A}$, $T_A = 25\sim 125^{\circ}\text{C}$	-12	± 8	+12	mV
		$I_{\text{P}}=0\text{A}$, $T_A = -40\sim 25^{\circ}\text{C}$	-15	± 10	+15	mV
TOTAL OUTPUT ERROR COMPONENTS: $E_{\text{TOT}} = \{[V_{\text{IOUT_ideal}}(I_{\text{PR}}) - V_{\text{IOUT}}(I_{\text{PR}})] / [\text{Sens}_{\text{Ideal}} * I_{\text{PR}}]\} * 100\%$						
Total Output Error	E_{TOT}	$I_{\text{PR}} = \pm 35\text{A}$, $T_A = 25^{\circ}\text{C}$	-1.5	± 1	+1.5	%
		$I_{\text{PR}} = \pm 35\text{A}$, $T_A = 25^{\circ}\text{C} \sim 125^{\circ}\text{C}$	-2	± 1.5	+2	%
		$I_{\text{PR}} = \pm 35\text{A}$, $T_A = -40^{\circ}\text{C} \sim 25^{\circ}\text{C}$	-2	± 1.5	+2	%
Accuracy of overcurrent fault threshold						
Fast fault output	$E_{\text{IFLAG_F}}$	$T_A = 25^{\circ}\text{C}$		± 15		%
		$T_A = -40^{\circ}\text{C} \sim 125^{\circ}\text{C}$		± 25		%
Slow fault output	$E_{\text{IFLAG_S}}$	$\text{Max}=2/\text{Sens} * 2$, $T_A = 25^{\circ}\text{C}$		± 15		%
		$\text{Max}=2/\text{Sens} * 2$, $T_A = -40^{\circ}\text{C} \sim 125^{\circ}\text{C}$		± 25		%

[1] The typical value is +/-1 sigma, and 68.27% of products fall within this range; The maximum/minimum value is +/-3 sigma value, and 99.73% of products fall within this range

[2] For details about the relationship between the IFLAG_S overcurrent trigger threshold and OC_SET, see "The Relationship between OC_SET Pins and FLAG_S".

High Accuracy Current Sensor with Pin-Selectable Gains and Adjustable Overcurrent Fault Detection

SC824BFT-65G5 Individual Performance Characteristics

Note: Over full range of $T_A=25^{\circ}\text{C}$, $C_{\text{Bypass}}=0.47\mu\text{F}$, $C_{\text{Load}}=1\text{nF}$, $V_{\text{CC}}=5\text{V}$

Parameter	Symbol	Test Conditions	Min	Typ ^[1]	Max	Unit
NOMINAL PERFORMANCE (Regardless of life time drift error)						
Current-Sensing Range	I_{PR}		-65		65	A
$I_{\text{P}}=0\text{A}$, V_{IOUT} output voltage	V_{OQ}	$I_{\text{P}}=0\text{A}$		1.5		V
VREF output voltage	V_{ref}	Independent of the IP input current		1.5		V
Sensitivity	Sens	$-65\text{A} < I_{\text{P}} < 65\text{A}$		20.5		mV/A
Fast flow threshold range	$I_{\text{FLAG}}(I_{\text{F}})$	Built-in overcurrent threshold (Built-in 10)		122		A
Low speed overflow threshold range ^[2]	$I_{\text{FLAG}}(I_{\text{S}})$	$\text{Min}=2/\text{Sens} * 0.75$, $\text{Max}=2/\text{Sens} * 2$,	73.2		195	A
ACCURACY PERFORMANCE						
Sensitivity Error	E_{SENS}	$I_{\text{P}} = \pm 65\text{A}$, $T_A = 25^{\circ}\text{C}$	-1.2	± 0.8	+1.2	%
		$I_{\text{P}} = \pm 65\text{A}$, $T_A = 25 \sim 125^{\circ}\text{C}$	-1.5	± 1.2	+1.5	%
		$I_{\text{P}} = \pm 65\text{A}$, $T_A = -40 \sim 25^{\circ}\text{C}$	-2	± 1.5	+2	%
Single output zero error	E_{VOQ}	$I_{\text{P}}=0\text{A}$, $T_A = 25^{\circ}\text{C}$	-10	± 8	+10	mV
		$I_{\text{P}}=0\text{A}$, $T_A = 25 \sim 125^{\circ}\text{C}$	-12	± 8	+12	mV
		$I_{\text{P}}=0\text{A}$, $T_A = -40 \sim 25^{\circ}\text{C}$	-15	± 10	+15	mV
Differential Output zero Error	E_{VOE}	$I_{\text{P}}=0\text{A}$, $T_A = 25^{\circ}\text{C}$	-10	± 8	+10	mV
		$I_{\text{P}}=0\text{A}$, $T_A = 25 \sim 125^{\circ}\text{C}$	-12	± 8	+12	mV
		$I_{\text{P}}=0\text{A}$, $T_A = -40 \sim 25^{\circ}\text{C}$	-15	± 10	+15	mV
TOTAL OUTPUT ERROR COMPONENTS: $E_{\text{TOT}} = \{[V_{\text{IOUT_ideal}}(I_{\text{PR}}) - V_{\text{IOUT}}(I_{\text{PR}})] / [\text{Sens}_{\text{Ideal}} * I_{\text{PR}}]\} * 100\%$						
Total Output Error	E_{TOT}	$I_{\text{P}} = \pm 65\text{A}$, $T_A = 25^{\circ}\text{C}$	-1.5	± 0.8	+1.5	%
		$I_{\text{P}} = \pm 65\text{A}$, $T_A = 25^{\circ}\text{C} \sim 125^{\circ}\text{C}$	-1.8	± 1.2	+1.8	%
		$I_{\text{P}} = \pm 65\text{A}$, $T_A = -40^{\circ}\text{C} \sim 25^{\circ}\text{C}$	-2	± 1.5	+2	%
Accuracy of overcurrent fault threshold						
Fast fault output	$E_{\text{IFLAG_F}}$	$T_A = 25^{\circ}\text{C}$		± 15		%
		$T_A = -40^{\circ}\text{C} \sim 125^{\circ}\text{C}$		± 25		%
Slow fault output	$E_{\text{IFLAG_S}}$	$\text{Max}=2/\text{Sens} * 2$, $T_A = 25^{\circ}\text{C}$		± 15		%
		$\text{Max}=2/\text{Sens} * 2$, $T_A = -40^{\circ}\text{C} \sim 125^{\circ}\text{C}$		± 25		%

[1] The typical value is +/-1 sigma, and 68.27% of products fall within this range; The maximum/minimum value is +/-3 sigma value, and 99.73% of products fall within this range

[2] For details about the relationship between the IFLAG_S overcurrent trigger threshold and OC_SET, see "The Relationship between OC_SET Pins and FLAG_S".

High Accuracy Current Sensor with Pin-Selectable Gains and Adjustable Overcurrent Fault Detection

SC824CGT-50F5 Individual Performance Characteristics

Note: Over full range of $T_A=25^{\circ}\text{C}$, $C_{\text{Bypass}}=0.47\mu\text{F}$, $C_{\text{Load}}=1\text{nF}$, $V_{\text{CC}}=5\text{V}$

SC824CGT-50F5 Gain selection Configuration

	GAIN_SEL_1 (Digital inputs)	GAIN_SEL_0 (Digital inputs)	Sensitivity (mV/A)	Maximum sense current (A)
Gain Combinations	0	0	40	50
	0	1	80	25
	1	0	160	12.5
	1	1	40	50

Note: 0 is a pull-down / 1 is a hanging or pull-up.

Parameter	Symbol	Test Conditions	Min	Typ ^[1]	Max	Unit
NOMINAL PERFORMANCE (Regardless of life time drift error)						
Current-Sensing Range	IPR	GAIN_SEL 00	-50		50	A
		GAIN_SEL 01	-25		25	A
		GAIN_SEL 10	-12.5		12.5	A
		GAIN_SEL 11	-50		50	A
IP=0A , VIOUT output voltage	VOQ	IP=0A		2.5		V
VREF output voltage	Vref	Independent of the IP input current		2.5		V
Sensitivity	Sens	GAIN_SEL 00 , IPR(MIN)<IPR< IPR(MAX)		40		mV/A
		GAIN_SEL 01 , IPR(MIN)<IPR< IPR(MAX)		80		mV/A
		GAIN_SEL 10 , IPR(MIN)<IPR< IPR(MAX)		160		mV/A
		GAIN_SEL 11 , IPR(MIN)<IPR< IPR(MAX)		40		mV/A
Low speed overflow threshold range ^[2]	IFLAG_S	Min=IPR *0.75, Max= IPR *2,	0.75*IPR		2*IPR	A
ACCURACY PERFORMANCE						
Sensitivity Error	ESENS	IPR = ±50 A, TA = 25°C		±1		%
		IPR = ±50 A, TA = 25~125°C		±2		%
		IPR = ±50 A, TA = 125~150°C		±2		%
		IPR = ±50 A, TA = - 40~25°C		±2		%
Single output zero error	EVOQ	IP=0A, TA = 25°C		±5		mV
		IP=0A, TA = 25~125°C		±10		mV
		IP=0A, TA = 125~150°C		±5		mV
		IP=0A, TA = - 40~25°C		±10		mV
Differential Output zero Error	EVOE	IP=0A, TA = 25°C		±5		mV
		IP=0A, TA = 25~125°C		±10		mV
		IP=0A, TA = 125~150°C		±5		mV
		IP=0A, TA = - 40~25°C		±10		mV
TOTAL OUTPUT ERROR COMPONENTS: $E_{\text{TOT}} = \{[V_{\text{IOUT_ideal}}(\text{IPR}) - V_{\text{IOUT}}(\text{IPR})] / [\text{Sens}_{\text{ideal}} * \text{IPR}]\} * 100\%$						
Total Output Error	ETOT	IPR = ±50 A, TA=25°C		±1		%
		IPR = ±50 A, TA=25°C~125°C		±2		%
		IPR = ±50 A, TA=125°C~150°C		±2		%
		IPR = ±50 A, TA= - 40°C ~ 25°C		±2		%
Accuracy of overcurrent fault threshold						
Slow fault output	EIFLAG_S	Max=IPR *2 , TA = 25°C		±15		%
		Max=IPR *2 , TA=25°C~125°C		±25		%
		Max=IPR *2 , TA=125°C~150°C		±25		%
		Max=IPR *2 , TA=-40°C~25°C		±25		%

[1] The typical value is +/-1 sigma, and 68.27% of products fall within this range; The maximum/minimum value is +/-3 sigma value, and 99.73% of products fall within this range

[2] For details about the relationship between the IFLAG_S overcurrent trigger threshold and OC_SET, see "The Relationship between OC_SET

High Accuracy Current Sensor with Pin-Selectable Gains and Adjustable Overcurrent Fault Detection

SC824CGT-75F5 Individual Performance Characteristics

Note: Over full range of $T_A=25^{\circ}\text{C}$, $C_{\text{Bypass}}=0.47\mu\text{F}$, $C_{\text{Load}}=1\text{nF}$, $V_{\text{CC}}=5\text{V}$

SC824CGT-75F5 Gain selection Configuration

	GAIN_SEL_1 (Digital inputs)	GAIN_SEL_0 (Digital inputs)	Sensitivity (mV/A)	Maximum sense current (A)
Gain Combinations	0	0	26.66	75
	0	1	53.33	37.5
	1	0	106.6	18.7
	1	1	26.66	75

Note: 0 is a pull-down / 1 is a hanging or pull-up.

Parameter	Symbol	Test Conditions	Min	Typ ^[1]	Max	Unit
NOMINAL PERFORMANCE (Regardless of life time drift error)						
Current-Sensing Range	IPR	GAIN_SEL 00	-75		75	A
		GAIN_SEL 01	-37.5		37.5	A
		GAIN_SEL 10	-18.7		18.7	A
		GAIN_SEL 11	-75		75	A
IP=0A , VIOUT output voltage	VOQ	IP=0A		2.5		V
VREF output voltage	Vref	Independent of the IP input current		2.5		V
Sensitivity	Sens	GAIN_SEL 00 , IPR(MIN)<IPR< IPR(MAX)		26.66		mV/A
		GAIN_SEL 01 , IPR(MIN)<IPR< IPR(MAX)		53.33		mV/A
		GAIN_SEL 10 , IPR(MIN)<IPR< IPR(MAX)		106.6		mV/A
		GAIN_SEL 11 , IPR(MIN)<IPR< IPR(MAX)		26.66		mV/A
Low speed overflow threshold range ^[2]	IFLAG_S	Min=IPR *0.75, Max= IPR *2,	0.75*IPR		2*IPR	A
ACCURACY PERFORMANCE						
Sensitivity Error	ESENS	IPR = ±75 A, TA = 25°C		±1		%
		IPR = ±75 A, TA = 25~125°C		±2		%
		IPR = ±75 A, TA = 125~150°C		±2		%
		IPR = ±75 A, TA = - 40~25°C		±2		%
Single output zero error	EVOQ	IP=0A, TA = 25°C		±5		mV
		IP=0A, TA = 25~125°C		±10		mV
		IP=0A, TA = 125~150°C		±5		mV
		IP=0A, TA = - 40~25°C		±10		mV
Differential Output zero Error	EVOE	IP=0A, TA = 25°C		±5		mV
		IP=0A, TA = 25~125°C		±10		mV
		IP=0A, TA = 125~150°C		±5		mV
		IP=0A, TA = - 40~25°C		±10		mV
TOTAL OUTPUT ERROR COMPONENTS: $E_{\text{TOT}} = \{[V_{\text{IOUT_ideal}}(\text{IPR}) - V_{\text{IOUT}}(\text{IPR})] / [\text{Sens}_{\text{ideal}} * \text{IPR}]\} * 100\%$						
Total Output Error	ETOT	IPR = ±75 A, TA=25°C		±1		%
		IPR = ±75 A, TA=25°C~125°C		±2		%
		IPR = ±75 A, TA=125°C~150°C		±2		%
		IPR = ±75 A, TA= - 40°C ~ 25°C		±2		%
Accuracy of overcurrent fault threshold						
Slow fault output	EIFLAG_S	Max=IPR *2 , TA = 25°C		±15		%
		Max=IPR *2 , TA=25°C~125°C		±25		%
		Max=IPR *2 , TA=125°C~150°C		±25		%
		Max=IPR *2 , TA=-40°C~25°C		±25		%

[1] The typical value is +/-1 sigma, and 68.27% of products fall within this range; The maximum/minimum value is +/-3 sigma value, and 99.73% of products fall within this range

[2] For details about the relationship between the IFLAG_S overcurrent trigger threshold and OC_SET, see "The Relationship between OC_SET Pins and FLAG_S".

High Accuracy Current Sensor with Pin-Selectable Gains and Adjustable Overcurrent Fault Detection

Pins and FLAG_S".

SC824CGT-80F5 Individual Performance Characteristics

Note: Over full range of $T_A=25^{\circ}\text{C}$, $C_{\text{Bypass}}=0.47\mu\text{F}$, $C_{\text{Load}}=1\text{nF}$, $V_{\text{CC}}=5\text{V}$

SC824CGT-80F5 Gain selection Configuration

	GAIN_SEL_1 (Digital inputs)	GAIN_SEL_0 (Digital inputs)	Sensitivity (mV/A)	Maximum sense current (A)
Gain Combinations	0	0	25	80
	0	1	50	40
	1	0	100	20
	1	1	200	10

Note: 0 is a pull-down / 1 is a hanging or pull-up.

Parameter	Symbol	Test Conditions	Min	Typ ^[1]	Max	Unit
NOMINAL PERFORMANCE (Regardless of life time drift error)						
Current-Sensing Range	IPR	GAIN_SEL 00	-80		80	A
		GAIN_SEL 01	-40		40	A
		GAIN_SEL 10	-20		20	A
		GAIN_SEL 11	-10		10	A
IP=0A, VIOUT output voltage	VOQ	IP=0A		2.5		V
VREF output voltage	Vref	Independent of the IP input current		2.5		V
Sensitivity	Sens	GAIN_SEL 00, IPR(MIN)<IPR<IPR(MAX)		25		mV/A
		GAIN_SEL 01, IPR(MIN)<IPR<IPR(MAX)		50		mV/A
		GAIN_SEL 10, IPR(MIN)<IPR<IPR(MAX)		100		mV/A
		GAIN_SEL 11, IPR(MIN)<IPR<IPR(MAX)		200		mV/A
Low speed overflow threshold range ^[2]	IFLAG_S	Min=IPR *0.75, Max= IPR *2,	0.75*IPR		2*IPR	A
ACCURACY PERFORMANCE						
Sensitivity Error	ESENS	IPR = ±80 A, TA = 25°C		±0.5		%
		IPR = ±80 A, TA = 25~125°C		±2		%
		IPR = ±80 A, TA = 125~150°C		±1.5		%
		IPR = ±80 A, TA = - 40~25°C		±2		%
Single output zero error	EVOQ	IP=0A, TA = 25°C		±5		mV
		IP=0A, TA = 25~125°C		±10		mV
		IP=0A, TA = 125~150°C		±5		mV
		IP=0A, TA = - 40~25°C		±10		mV
Differential Output zero Error	EVOE	IP=0A, TA = 25°C		±5		mV
		IP=0A, TA = 25~125°C		±10		mV
		IP=0A, TA = 125~150°C		±5		mV
		IP=0A, TA = - 40~25°C		±10		mV
TOTAL OUTPUT ERROR COMPONENTS: $E_{\text{TOT}} = \{[V_{\text{IOUT_ideal}}(\text{IPR}) - V_{\text{IOUT}}(\text{IPR})] / [\text{Sens}_{\text{ideal}} * \text{IPR}]\} * 100\%$						
Total Output Error	ETOT	IPR = ±80 A, TA=25°C		±1		%
		IPR = ±80 A, TA=25°C~125°C		±2		%
		IPR = ±80 A, TA=125°C~150°C		±2		%
		IPR = ±80 A, TA= - 40°C ~ 25°C		±2		%
Accuracy of overcurrent fault threshold						
Slow fault output	EIFLAG_S	Max=IPR *2, TA= 25°C		±15		%
		Max=IPR *2, TA=25°C~125°C		±25		%
		Max=IPR *2, TA=125°C~150°C		±25		%
		Max=IPR *2, TA=-40°C~25°C		±25		%

[1] The typical value is +/-1 sigma, and 68.27% of products fall within this range; The maximum/minimum value is +/-3 sigma value, and 99.73% of products fall within this range

[2] For details about the relationship between the IFLAG_S overcurrent trigger threshold and OC_SET, see "The Relationship between OC_SET Pins and FLAG_S".

High Accuracy Current Sensor with Pin-Selectable Gains and Adjustable Overcurrent Fault Detection

SC824CGT-30F3 Individual Performance Characteristics

Note: Over full range of $T_A=25^{\circ}\text{C}$, $C_{\text{Bypass}}=0.47\mu\text{F}$, $C_{\text{Load}}=1\text{nF}$, $V_{\text{CC}}=3.3\text{V}$

SC824CGT-30F3 Gain selection Configuration

	GAIN_SEL_1 (Digital inputs)	GAIN_SEL_0 (Digital inputs)	Sensitivity (mV/A)	Maximum sense current (A)
Gain Combinations	0	0	44	30
	0	1	88	15
	1	0	176	7.5
	1	1	44	30

Note: 0 is a pull-down / 1 is a hanging or pull-up. The built-in setting is 11

Parameter	Symbol	Test Conditions	Min	Typ ^[1]	Max	Unit
NOMINAL PERFORMANCE (Regardless of life time drift error)						
Current-Sensing Range	IPR	GAIN_SEL 00	-30		30	A
		GAIN_SEL 01	-15		15	A
		GAIN_SEL 10	-7.5		7.5	A
		GAIN_SEL 11	-30		30	A
IP=0A , VIOUT output voltage	VOQ	IP=0A		2.5		V
VREF output voltage	Vref	Independent of the IP input current		2.5		V
Sensitivity	Sens	GAIN_SEL 00 , IPR(MIN)<IPR< IPR(MAX)		44		mV/A
		GAIN_SEL 01 , IPR(MIN)<IPR< IPR(MAX)		88		mV/A
		GAIN_SEL 10 , IPR(MIN)<IPR< IPR(MAX)		176		mV/A
		GAIN_SEL 11 , IPR(MIN)<IPR< IPR(MAX)		44		mV/A
Low speed overflow threshold range ^[2]	IFLAG_S	Min=IPR *0.75, Max= IPR *2,	0.75*IPR		2*IPR	A
ACCURACY PERFORMANCE						
Sensitivity Error	ESENS	IPR = ±30 A, TA = 25°C		±1		%
		IPR = ±30 A, TA = 25~125°C		±1		%
		IPR = ±30 A, TA = 125~150°C		±1.5		%
		IPR = ±30 A, TA = - 40~25°C		±1		%
Single output zero error	EVOQ	Ip=0A, TA = 25°C		±5		mV
		Ip=0A, TA = 25~125°C		±10		mV
		Ip=0A, TA = 125~150°C		±5		mV
		Ip=0A, TA = - 40~25°C		±10		mV
Differential Output zero Error	EVOE	Ip=0A, TA = 25°C		±5		mV
		Ip=0A, TA = 25~125°C		±10		mV
		Ip=0A, TA = 125~150°C		±5		mV
		Ip=0A, TA = - 40~25°C		±10		mV
TOTAL OUTPUT ERROR COMPONENTS: $E_{\text{TOT}} = \{[V_{\text{IOUT_ideal}}(\text{IPR}) - V_{\text{IOUT}}(\text{IPR})] / [\text{Sens}_{\text{ideal}} * \text{IPR}] \} * 100\%$						
Total Output Error	ETOT	IPR = ±30 A, TA=25°C		±1		%
		IPR = ±30 A, TA=25°C~125°C		±2		%
		IPR = ±30 A, TA=125°C~150°C		±2		%
		IPR = ±30 A, TA= - 40°C ~ 25°C		±2		%
Accuracy of overcurrent fault threshold						
Slow fault output	EIFLAG_S	Max=IPR *2 ,TA= 25°C		±15		%
		Max=IPR *2 , TA=25°C~125°C		±25		%
		Max=IPR *2 , TA=125°C~150°C		±25		%
		Max=IPR *2 , TA=-40°C~25°C		±25		%

[1] The typical value is +/-1 sigma, and 68.27% of products fall within this range; The maximum/minimum value is +/-3 sigma value, and 99.73% of products fall within this range

[2] For details about the relationship between the IFLAG_S overcurrent trigger threshold and OC_SET, see "The Relationship between OC_SET Pins and FLAG_S".

High Accuracy Current Sensor with Pin-Selectable Gains and Adjustable Overcurrent Fault Detection

SC824CGT-40F3 Individual Performance Characteristics

Note: Over full range of $T_A=25^{\circ}\text{C}$, $C_{\text{Bypass}}=0.47\mu\text{F}$, $C_{\text{Load}}=1\text{nF}$, $V_{\text{CC}}=3.3\text{V}$

SC824CGT-40F3 Gain selection Configuration

	GAIN_SEL_1 (Digital inputs)	GAIN_SEL_0 (Digital inputs)	Sensitivity (mV/A)	Maximum sense current (A)
Gain Combinations	0	0	33	40
	0	1	66	20
	1	0	132	10
	1	1	33	40

Note: 0 is a pull-down / 1 is a hanging or pull-up. The built-in setting is 11

Parameter	Symbol	Test Conditions	Min	Typ ^[1]	Max	Unit
NOMINAL PERFORMANCE (Regardless of life time drift error)						
Current-Sensing Range	IPR	GAIN_SEL 00	-40		40	A
		GAIN_SEL 01	-20		20	A
		GAIN_SEL 10	-10		10	A
		GAIN_SEL 11	-40		40	A
IP=0A, VIOUT output voltage	VOQ	IP=0A		2.5		V
VREF output voltage	Vref	Independent of the IP input current		2.5		V
Sensitivity	Sens	GAIN_SEL 00 , IPR(MIN)<IPR< IPR(MAX)		33		mV/A
		GAIN_SEL 01 , IPR(MIN)<IPR< IPR(MAX)		66		mV/A
		GAIN_SEL 10 , IPR(MIN)<IPR< IPR(MAX)		132		mV/A
		GAIN_SEL 11 , IPR(MIN)<IPR< IPR(MAX)		33		mV/A
Low speed overflow threshold range ^[2]	IFLAG_S	Min=IPR *0.75, Max= IPR *2,	0.75*IPR		2*IPR	A
ACCURACY PERFORMANCE						
Sensitivity Error	ESENS	IPR = ±40 A, TA = 25°C		±1		%
		IPR = ±40 A, TA = 25~125°C		±1		%
		IPR = ±40 A, TA = 125~150°C		±1.5		%
		IPR = ±40 A, TA = - 40~25°C		±1		%
Single output zero error	EVOQ	Ip=0A, TA = 25°C		±5		mV
		Ip=0A, TA = 25~125°C		±10		mV
		Ip=0A, TA = 125~150°C		±5		mV
		Ip=0A, TA = - 40~25°C		±10		mV
Differential Output zero Error	EVOE	Ip=0A, TA = 25°C		±5		mV
		Ip=0A, TA = 25~125°C		±10		mV
		Ip=0A, TA = 125~150°C		±5		mV
		Ip=0A, TA = - 40~25°C		±10		mV
TOTAL OUTPUT ERROR COMPONENTS: $E_{\text{TOT}} = \{[V_{\text{IOUT_ideal}}(\text{IPR}) - V_{\text{IOUT}}(\text{IPR})] / [\text{Sens}_{\text{ideal}} * \text{IPR}]\} * 100\%$						
Total Output Error	ETOT	IPR = ±40 A, TA=25°C		±1		%
		IPR = ±40 A, TA=25°C~125°C		±2		%
		IPR = ±40 A, TA=125°C~150°C		±2		%
		IPR = ±40 A, TA= - 40°C ~ 25°C		±2		%
Accuracy of overcurrent fault threshold						
Slow fault output	EIFLAG_S	Max=IPR *2 ,TA= 25°C		±15		%
		Max=IPR *2 , TA=25°C~125°C		±25		%
		Max=IPR *2 , TA=125°C~150°C		±25		%
		Max=IPR *2 , TA=-40°C~25°C		±25		%

[1] The typical value is +/-1 sigma, and 68.27% of products fall within this range; The maximum/minimum value is +/-3 sigma value, and 99.73% of products fall within this range

[2] For details about the relationship between the IFLAG_S overcurrent trigger threshold and OC_SET, see "The Relationship between OC_SET Pins and FLAG_S".

High Accuracy Current Sensor with Pin-Selectable Gains and Adjustable Overcurrent Fault Detection

SC824CGT-65F3 Individual Performance Characteristics

Note: Over full range of $T_A=25^{\circ}\text{C}$, $C_{\text{Bypass}}=0.47\mu\text{F}$, $C_{\text{Load}}=1\text{nF}$, $V_{\text{CC}}=3.3\text{V}$

SC824CGT-65F3 Gain selection Configuration

	GAIN_SEL_1 (Digital inputs)	GAIN_SEL_0 (Digital inputs)	Sensitivity (mV/A)	Maximum sense current (A)
Gain Combinations	0	0	20.31	65
	0	1	40.62	32.5
	1	0	81.24	16.25
	1	1	20.31	65

Note: 0 is a pull-down / 1 is a hanging or pull-up. The built-in setting is 11

Parameter	Symbol	Test Conditions	Min	Typ ^[1]	Max	Unit
NOMINAL PERFORMANCE (Regardless of life time drift error)						
Current-Sensing Range	IPR	GAIN_SEL 00	-65		65	A
		GAIN_SEL 01	-32.5		32.5	A
		GAIN_SEL 10	-16.25		16.25	A
		GAIN_SEL 11	-65		65	A
IP=0A, VIOUT output voltage	VOQ	IP=0A		2.5		V
VREF output voltage	Vref	Independent of the IP input current		2.5		V
Sensitivity	Sens	GAIN_SEL 00 , IPR(MIN)<IPR< IPR(MAX)		20.31		mV/A
		GAIN_SEL 01 , IPR(MIN)<IPR< IPR(MAX)		40.62		mV/A
		GAIN_SEL 10 , IPR(MIN)<IPR< IPR(MAX)		81.24		mV/A
		GAIN_SEL 11 , IPR(MIN)<IPR< IPR(MAX)		20.31		mV/A
Low speed overflow threshold range ^[2]	IFLAG_S	Min=IPR *0.75, Max= IPR *2,	0.75*IPR		2*IPR	A
ACCURACY PERFORMANCE						
Sensitivity Error	ESENS	IPR = ±65 A, TA = 25°C		±1		%
		IPR = ±65 A, TA = 25~125°C		±1		%
		IPR = ±65 A, TA = 125~150°C		±1.5		%
		IPR = ±65 A, TA = - 40~25°C		±1		%
Single output zero error	EVOQ	IP=0A, TA = 25°C		±5		mV
		IP=0A, TA = 25~125°C		±10		mV
		IP=0A, TA = 125~150°C		±5		mV
		IP=0A, TA = - 40~25°C		±10		mV
Differential Output zero Error	EVOE	IP=0A, TA = 25°C		±5		mV
		IP=0A, TA = 25~125°C		±10		mV
		IP=0A, TA = 125~150°C		±5		mV
		IP=0A, TA = - 40~25°C		±10		mV
TOTAL OUTPUT ERROR COMPONENTS: $E_{\text{TOT}} = \{[V_{\text{IOUT_ideal}}(\text{IPR}) - V_{\text{IOUT}}(\text{IPR})] / [\text{Sens}_{\text{ideal}} * \text{IPR}]\} * 100\%$						
Total Output Error	ETOT	IPR = ±65 A, TA=25°C		±1		%
		IPR = ±65 A, TA=25°C~125°C		±2		%
		IPR = ±65 A, TA=125°C~150°C		±2		%
		IPR = ±65 A, TA= - 40°C ~ 25°C		±2		%
Accuracy of overcurrent fault threshold						
Slow fault output	EIFLAG_S	Max=IPR *2 ,TA= 25°C		±15		%
		Max=IPR *2 , TA=25°C~125°C		±25		%
		Max=IPR *2 , TA=125°C~150°C		±25		%
		Max=IPR *2 , TA=-40°C~25°C		±25		%

[1] The typical value is +/-1 sigma, and 68.27% of products fall within this range; The maximum/minimum value is +/-3 sigma value, and 99.73% of products fall within this range

[2] For details about the relationship between the IFLAG_S overcurrent trigger threshold and OC_SET, see "The Relationship between OC_SET Pins and FLAG_S".

High Accuracy Current Sensor with Pin-Selectable Gains and Adjustable Overcurrent Fault Detection

SC824CGT-66F5 Individual Performance Characteristics

Note: Over full range of $T_A=25^{\circ}\text{C}$, $C_{\text{Bypass}}=0.47\mu\text{F}$, $C_{\text{Load}}=1\text{nF}$, $V_{\text{CC}}=5\text{V}$

SC824CGT-66F5 Gain selection Configuration

	GAIN_SEL_1 (Digital inputs)	GAIN_SEL_0 (Digital inputs)	Sensitivity (mV/A)	Maximum sense current (A)
Gain Combinations	0	0	30	66.7
	0	1	60	33.33
	1	0	120	16.66
	1	1	30	66.7

Note: 0 is a pull-down / 1 is a hanging or pull-up. The built-in setting is 11

Parameter	Symbol	Test Conditions	Min	Typ ^[1]	Max	Unit
NOMINAL PERFORMANCE (Regardless of life time drift error)						
Current-Sensing Range	IPR	GAIN_SEL 00	-66.7		66.7	A
		GAIN_SEL 01	-33.33		33.33	A
		GAIN_SEL 10	-16.66		16.66	A
		GAIN_SEL 11	-66.7		66.7	A
IP=0A, VIOUT output voltage	VOQ	IP=0A		2.5		V
VREF output voltage	Vref	Independent of the IP input current		2.5		V
Sensitivity	Sens	GAIN_SEL 00, IPR(MIN)<IPR<IPR(MAX)		30		mV/A
		GAIN_SEL 01, IPR(MIN)<IPR<IPR(MAX)		60		mV/A
		GAIN_SEL 10, IPR(MIN)<IPR<IPR(MAX)		120		mV/A
		GAIN_SEL 11, IPR(MIN)<IPR<IPR(MAX)		30		mV/A
Low speed overflow threshold range ^[2]	IFLAG_S	Min=IPR *0.75, Max= IPR *2,	0.75*IPR		2*IPR	A
ACCURACY PERFORMANCE						
Sensitivity Error	ESENS	IPR = ±66.7 A, TA = 25°C		±1		%
		IPR = ±66.7 A, TA = 25~125°C		±1		%
		IPR = ±66.7 A, TA = 125~150°C		±1.5		%
		IPR = ±66.7 A, TA = - 40~25°C		±1		%
Single output zero error	EVOQ	IP=0A, TA = 25°C		±5		mV
		IP=0A, TA = 25~125°C		±10		mV
		IP=0A, TA = 125~150°C		±5		mV
		IP=0A, TA = - 40~25°C		±10		mV
Differential Output zero Error	EVOE	IP=0A, TA = 25°C		±5		mV
		IP=0A, TA = 25~125°C		±10		mV
		IP=0A, TA = 125~150°C		±5		mV
		IP=0A, TA = - 40~25°C		±10		mV
TOTAL OUTPUT ERROR COMPONENTS: $E_{\text{TOT}} = \{[V_{\text{IOUT_ideal}}(\text{IPR}) - V_{\text{IOUT}}(\text{IPR})] / [\text{Sens}_{\text{ideal}} * \text{IPR}]\} * 100\%$						
Total Output Error	ETOT	IPR = ±66.7 A, TA=25°C		±1		%
		IPR = ±66.7 A, TA=25°C~125°C		±2		%
		IPR = ±66.7 A, TA=125°C~150°C		±2		%
		IPR = ±66.7 A, TA= - 40°C ~ 25°C		±2		%
Accuracy of overcurrent fault threshold						
Slow fault output	EIFLAG_S	Max=IPR *2 ,TA= 25°C		±15		%
		Max=IPR *2 , TA=25°C~125°C		±25		%
		Max=IPR *2 , TA=125°C~150°C		±25		%
		Max=IPR *2 , TA=-40°C~25°C		±25		%

[1] The typical value is +/-1 sigma, and 68.27% of products fall within this range; The maximum/minimum value is +/-3 sigma value, and 99.73% of products fall within this range

[2] For details about the relationship between the IFLAG_S overcurrent trigger threshold and OC_SET, see "The Relationship between OC_SET Pins and FLAG_S".

High Accuracy Current Sensor with Pin-Selectable Gains and Adjustable Overcurrent Fault Detection

SC824CGT-133F5 Individual Performance Characteristics

Note: Over full range of $T_A=25^{\circ}\text{C}$, $C_{\text{Bypass}}=0.47\mu\text{F}$, $C_{\text{Load}}=1\text{nF}$, $V_{\text{CC}}=5\text{V}$

SC824CGT-133F5 Gain selection Configuration

	GAIN_SEL_1 (Digital inputs)	GAIN_SEL_0 (Digital inputs)	Sensitivity (mV/A)	Maximum sense current (A)
Gain Combinations	0	0	15	133
	0	1	30	66.7
	1	0	60	33.3
	1	1	15	133.3

Note: 0 is a pull-down / 1 is a hanging or pull-up. The built-in setting is 1X

Parameter	Symbol	Test Conditions	Min	Typ ^[1]	Max	Unit
NOMINAL PERFORMANCE (Regardless of life time drift error)						
Current-Sensing Range	IPR	GAIN_SEL 00	-133.3		133.3	A
		GAIN_SEL 01	-66.7		66.7	A
		GAIN_SEL 10	-33.3		33.3	A
		GAIN_SEL 11	-133.3		133.3	A
IP=0A, VIOOUT output voltage	VOQ	IP=0A		2.5		V
VREF output voltage	Vref	Independent of the IP input current		2.5		V
Sensitivity	Sens	GAIN_SEL 00, IPR(MIN)<IPR<IPR(MAX)		15		mV/A
		GAIN_SEL 01, IPR(MIN)<IPR<IPR(MAX)		30		mV/A
		GAIN_SEL 10, IPR(MIN)<IPR<IPR(MAX)		60		mV/A
		GAIN_SEL 11, IPR(MIN)<IPR<IPR(MAX)		15		mV/A
Low speed overflow threshold range ^[2]	IFLAG_S	Min=IPR *0.75, Max= IPR *2,	0.75*IPR		2*IPR	A
ACCURACY PERFORMANCE						
Sensitivity Error	ESENS	IPR = ±133 A, TA = 25°C		±1.5		%
		IPR = ±133 A, TA = 25~125°C		±2		%
		IPR = ±133 A, TA = 125~150°C		±4.5		%
		IPR = ±133 A, TA = - 40~25°C		±3		%
Single output zero error	EVOQ	IP=0A, TA = 25°C		±5		mV
		IP=0A, TA = 25~125°C		±10		mV
		IP=0A, TA = 125~150°C		±5		mV
		IP=0A, TA = - 40~25°C		±10		mV
Differential Output zero Error	EVOE	IP=0A, TA = 25°C		±5		mV
		IP=0A, TA = 25~125°C		±10		mV
		IP=0A, TA = 125~150°C		±15		mV
		IP=0A, TA = - 40~25°C		±10		mV
TOTAL OUTPUT ERROR COMPONENTS: $E_{\text{TOT}} = \{[V_{\text{IOUT_ideal}}(\text{IPR}) - V_{\text{IOUT}}(\text{IPR})] / [\text{Sens}_{\text{ideal}} * \text{IPR}]\} * 100\%$						
Total Output Error	ETOT	IPR = ±133 A, TA=25°C		±2		%
		IPR = ±133 A, TA=25°C~125°C		±2.5		%
		IPR = ±133 A, TA=125°C~150°C		±5.5		%
		IPR = ±133 A, TA= - 40°C ~ 25°C		±3		%
Accuracy of overcurrent fault threshold						
Slow fault output	EIFLAG_S	Max=IPR *2 ,TA= 25°C		±15		%
		Max=IPR *2 , TA=25°C~125°C		±25		%
		Max=IPR *2 , TA=125°C~150°C		±25		%
		Max=IPR *2 , TA=-40°C~25°C		±25		%

[1] The typical value is +/-1 sigma, and 68.27% of products fall within this range; The maximum/minimum value is +/-3 sigma value, and 99.73% of products fall within this range

[2] For details about the relationship between the IFLAG_S overcurrent trigger threshold and OC_SET, see "The Relationship between OC_SET Pins and FLAG_S".

High Accuracy Current Sensor with Pin-Selectable Gains and Adjustable Overcurrent Fault Detection

SC825CGT-65U3 Individual Performance Characteristics

Note: Over full range of $T_A=25^{\circ}\text{C}$, $C_{\text{Bypass}}=0.47\mu\text{F}$, $C_{\text{Load}}=1\text{nF}$, $V_{\text{CC}}=3.3\text{V}$

SC825CGT-65U3 Gain selection Configuration

	GAIN_SEL_1 (Digital inputs)	GAIN_SEL_0 (Digital inputs)	Sensitivity (mV/A)	Maximum sense current (A)
Gain Combinations	0	0	40.61	65
	0	1	81.22	32.5
	1	0	162.44	16.25
	1	1	40.61	65

Note: 0 is a pull-down / 1 is a hanging or pull-up. The built-in setting is 11

Parameter	Symbol	Test Conditions	Min	Typ ^[1]	Max	Unit
NOMINAL PERFORMANCE (Regardless of life time drift error)						
Current-Sensing Range	IPR	GAIN_SEL 00	0		65	A
		GAIN_SEL 01	0		32.5	A
		GAIN_SEL 10	0		16.25	A
		GAIN_SEL 11	0		65	A
IP=0A, VIOUT output voltage	VOQ	IP=0A		0.1Vcc		V
VREF output voltage	Vref	Independent of the IP input current		0.1Vcc		V
Sensitivity	Sens	GAIN_SEL 00, IPR(MIN)<IPR<IPR(MAX)		65		mV/A
		GAIN_SEL 01, IPR(MIN)<IPR<IPR(MAX)		32.5		mV/A
		GAIN_SEL 10, IPR(MIN)<IPR<IPR(MAX)		16.25		mV/A
		GAIN_SEL 11, IPR(MIN)<IPR<IPR(MAX)		65		mV/A
Low speed overflow threshold range ^[2]	IFLAG_S	Min=IPR *0.75, Max= IPR *2,	0.75*IPR		2*IPR	A
ACCURACY PERFORMANCE						
Sensitivity Error	ESENS	IPR = +65 A, TA = 25°C		±0.5		%
		IPR = +65 A, TA = 25~125°C		±2		%
		IPR = +65 A, TA=125°C~150°C		±1.5		%
		IPR = +65 A, TA = - 40~25°C		±2		%
Single output zero error	EVOQ	IP=0A, TA = 25°C		±5		mV
		IP=0A, TA = 25~125°C		±10		mV
		IP=0A, TA=125°C~150°C		±5		mV
		IP=0A, TA = - 40~25°C		±10		mV
Differential Output zero Error	EVOE	IP=0A, TA = 25°C		±5		mV
		IP=0A, TA = 25~125°C		±10		mV
		IP=0A, TA=125°C~150°C		±5		mV
		IP=0A, TA = - 40~25°C		±10		mV
TOTAL OUTPUT ERROR COMPONENTS: $E_{\text{TOT}} = \{[V_{\text{IOUT_ideal}}(\text{IPR}) - V_{\text{IOUT}}(\text{IPR})] / [\text{Sens}_{\text{ideal}} * \text{IPR}]\} * 100\%$						
Total Output Error	ETOT	IPR = +65 A, TA=25°C		±1		%
		IPR = +65 A, TA=25°C~125°C		±2		%
		IPR = +65 A, TA=125°C~150°C		±2		%
		IPR = +65 A, TA = - 40°C ~ 25°C		±2		%
Accuracy of overcurrent fault threshold						
Slow fault output	EIFLAG_S	Max=IPR *2, TA= 25°C		±15		%
		Max=IPR *2, TA=25°C~125°C		±25		%
		Max=IPR *2, TA=125°C~150°C		±25		%
		Max=IPR *2, TA=-40°C~25°C		±25		%

[1] The typical value is +/-1 sigma, and 68.27% of products fall within this range; The maximum/minimum value is +/-3 sigma value, and 99.73% of products fall within this range

[2] For details about the relationship between the IFLAG_S overcurrent trigger threshold and OC_SET, see "The Relationship between OC_SET Pins and FLAG_S".

High Accuracy Current Sensor with Pin-Selectable Gains and Adjustable Overcurrent Fault Detection

SC824DFT-20F5 Individual Performance Characteristics

Note: Over full range of $T_A=25^{\circ}\text{C}$, $C_{\text{Bypass}}=0.47\mu\text{F}$, $C_{\text{Load}}=1\text{nF}$, $V_{\text{CC}}=5\text{V}$

Parameter	Symbol	Test Conditions	Min	Typ ^[1]	Max	Unit
NOMINAL PERFORMANCE (Regardless of life time drift error)						
Current-Sensing Range	I_{PR}		-20		20	A
IP=0A, V_{IOUT} output voltage	V_{OQ}	IP=0A		2.5		V
VREF output voltage	V_{ref}	Independent of the IP input current		2.5		V
Sensitivity	Sens	$-20\text{A} < \text{IP} < 20\text{A}$		100		mV/A
Fast overcurrent threshold range	IFLAG_F	Built-in Overcurrent Threshold (Built-in 10)		25		A
Low speed overflow threshold range ^[2]	IFLAG_S	Min= $I_{\text{PR}} * 0.75$, Max= $I_{\text{PR}} * 2$	15		40	A
ACCURACY PERFORMANCE						
Sensitivity Error	E_{SENS}	$I_{\text{PR}} = \pm 20\text{A}$, $T_A = 25^{\circ}\text{C}$	-1.5	± 0.5	+1.5	%
		$I_{\text{PR}} = \pm 20\text{A}$, $T_A = 25 \sim 125^{\circ}\text{C}$	-2.5	± 2	+2.5	%
		$I_{\text{PR}} = \pm 20\text{A}$, $T_A = -40 \sim 25^{\circ}\text{C}$	-2.5	± 2	+2.5	%
Single output zero error	E_{VOQ}	IP=0A, $T_A = 25^{\circ}\text{C}$	-10	± 5	+10	mV
		IP=0A, $T_A = 25 \sim 125^{\circ}\text{C}$	-20	± 10	+20	mV
		IP=0A, $T_A = -40 \sim 25^{\circ}\text{C}$	-20	± 10	+20	mV
Differential Output zero Error	E_{VOE}	IP=0A, $T_A = 25^{\circ}\text{C}$	-10	± 5	+10	mV
		IP=0A, $T_A = 25 \sim 125^{\circ}\text{C}$	-20	± 10	+20	mV
		IP=0A, $T_A = -40 \sim 25^{\circ}\text{C}$	-20	± 10	+20	mV
TOTAL OUTPUT ERROR COMPONENTS: $E_{\text{TOT}} = \{[V_{\text{IOUT_ideal}}(I_{\text{PR}}) - V_{\text{IOUT}}(I_{\text{PR}})] / [\text{Sens}_{\text{ideal}} * I_{\text{PR}}]\} * 100\%$						
Total Output Error	E_{TOT}	$I_{\text{PR}} = \pm 20\text{A}$, $T_A = 25^{\circ}\text{C}$	-1.5	± 1	+1.5	%
		$I_{\text{PR}} = \pm 20\text{A}$, $T_A = 25^{\circ}\text{C} \sim 125^{\circ}\text{C}$	-2.5	± 2	+2.5	%
		$I_{\text{PR}} = \pm 20\text{A}$, $T_A = -40^{\circ}\text{C} \sim 25^{\circ}\text{C}$	-2.5	± 2	+2.5	%
Accuracy of overcurrent fault threshold						
Fast fault output	$E_{\text{IFLAG_F}}$	$T_A = 25^{\circ}\text{C}$		± 15		%
		$T_A = -40^{\circ}\text{C} \sim 125^{\circ}\text{C}$		± 25		%
Slow fault output	$E_{\text{IFLAG_S}}$	Max= $I_{\text{PR}} * 2$, $T_A = 25^{\circ}\text{C}$		± 15		%
		Max= $I_{\text{PR}} * 2$, $T_A = -40^{\circ}\text{C} \sim 125^{\circ}\text{C}$		± 25		%

[1] The typical value is +/-1 sigma, and 68.27% of products fall within this range; The maximum/minimum value is +/-3 sigma value, and 99.73% of products fall within this range

[2] For details about the relationship between the IFLAG_S overcurrent trigger threshold and OC_SET, see "The Relationship between OC_SET Pins and FLAG_S".

High Accuracy Current Sensor with Pin-Selectable Gains and Adjustable Overcurrent Fault Detection

SC824DFT-30F5 Individual Performance Characteristics

Note: Over full range of $T_A=25^{\circ}\text{C}$, $C_{\text{Bypass}}=0.47\mu\text{F}$, $C_{\text{Load}}=1\text{nF}$, $V_{\text{CC}}=5\text{V}$

Parameter	Symbol	Test Conditions	Min	Typ ^[1]	Max	Unit
NOMINAL PERFORMANCE (Regardless of life time drift error)						
Current-Sensing Range	I_{PR}		-30		30	A
$I_{\text{P}}=0\text{A}$, V_{IOUT} output voltage	V_{OQ}	$I_{\text{P}}=0\text{A}$		2.5		V
VREF output voltage	V_{ref}	Independent of the I_{P} input current		2.5		V
Sensitivity	Sens	$-30\text{A} < I_{\text{P}} < 30\text{A}$		66		mV/A
Fast overcurrent threshold range	IFLAG_F	Built-in Overcurrent Threshold (Built-in 10)		37.5		A
Low speed overflow threshold range ^[2]	IFLAG_S	Min= $I_{\text{PR}} * 0.75$, Max= $I_{\text{PR}} * 2$	22.5		60	A
ACCURACY PERFORMANCE						
Sensitivity Error	E_{SENS}	$I_{\text{PR}} = \pm 30\text{A}$, $T_A = 25^{\circ}\text{C}$	-1.5	± 0.5	+1.5	%
		$I_{\text{PR}} = \pm 30\text{A}$, $T_A = 25\sim 125^{\circ}\text{C}$	-2.5	± 1	+2.5	%
		$I_{\text{PR}} = \pm 30\text{A}$, $T_A = -40\sim 25^{\circ}\text{C}$	-2.5	± 1.5	+2.5	%
Single output zero error	E_{VOQ}	$I_{\text{P}}=0\text{A}$, $T_A = 25^{\circ}\text{C}$	-10	± 5	+10	mV
		$I_{\text{P}}=0\text{A}$, $T_A = 25\sim 125^{\circ}\text{C}$	-20	± 10	+20	mV
		$I_{\text{P}}=0\text{A}$, $T_A = -40\sim 25^{\circ}\text{C}$	-20	± 10	+20	mV
Differential Output zero Error	E_{VOE}	$I_{\text{P}}=0\text{A}$, $T_A = 25^{\circ}\text{C}$	-10	± 5	+10	mV
		$I_{\text{P}}=0\text{A}$, $T_A = 25\sim 125^{\circ}\text{C}$	-20	± 10	+20	mV
		$I_{\text{P}}=0\text{A}$, $T_A = -40\sim 25^{\circ}\text{C}$	-20	± 10	+20	mV
TOTAL OUTPUT ERROR COMPONENTS: $E_{\text{TOT}} = \{[V_{\text{IOUT_ideal}}(I_{\text{PR}}) - V_{\text{IOUT}}(I_{\text{PR}})] / [\text{Sens}_{\text{ideal}} * I_{\text{PR}}]\} * 100\%$						
Total Output Error	E_{TOT}	$I_{\text{PR}} = \pm 30\text{A}$, $T_A = 25^{\circ}\text{C}$	-1.5	± 1	+1.5	%
		$I_{\text{PR}} = \pm 30\text{A}$, $T_A = 25^{\circ}\text{C} \sim 125^{\circ}\text{C}$	-2.5	± 2	+2.5	%
		$I_{\text{PR}} = \pm 30\text{A}$, $T_A = -40^{\circ}\text{C} \sim 25^{\circ}\text{C}$	-2.5	± 2	+2.5	%
Accuracy of overcurrent fault threshold						
Fast fault output	$E_{\text{IFLAG_F}}$	$T_A = 25^{\circ}\text{C}$		± 15		%
		$T_A = -40^{\circ}\text{C} \sim 125^{\circ}\text{C}$		± 25		%
Slow fault output	$E_{\text{IFLAG_S}}$	Max= $I_{\text{PR}} * 2$, $T_A = 25^{\circ}\text{C}$		± 15		%
		Max= $I_{\text{PR}} * 2$, $T_A = -40^{\circ}\text{C} \sim 125^{\circ}\text{C}$		± 25		%

[1] The typical value is ± 1 sigma, and 68.27% of products fall within this range; The maximum/minimum value is ± 3 sigma value, and 99.73% of products fall within this range

[2] For details about the relationship between the IFLAG_S overcurrent trigger threshold and OC_SET, see "The Relationship between OC_SET Pins and FLAG_S".

High Accuracy Current Sensor with Pin-Selectable Gains and Adjustable Overcurrent Fault Detection

SC824DFT-50F5 Individual Performance Characteristics

Note: Over full range of $T_A=25^{\circ}\text{C}$, $C_{\text{Bypass}}=0.47\mu\text{F}$, $C_{\text{Load}}=1\text{nF}$, $V_{\text{CC}}=5\text{V}$

Parameter	Symbol	Test Conditions	Min	Typ ^[1]	Max	Unit
NOMINAL PERFORMANCE (Regardless of life time drift error)						
Current-Sensing Range	I_{PR}		-50		50	A
IP=0A, V_{IOUT} output voltage	V_{OQ}	IP=0A		2.5		V
VREF output voltage	V_{ref}	Independent of the IP input current		2.5		V
Sensitivity	Sens	$-50\text{A} < \text{IP} < 50\text{A}$		40		mV/A
Fast overcurrent threshold range	IFLAG_F	Built-in Overcurrent Threshold (Built-in 10)		62.5		A
Low speed overflow threshold range ^[2]	IFLAG_S	Min= $I_{\text{PR}} * 0.75$, Max= $I_{\text{PR}} * 2$,	37.5		100	A
ACCURACY PERFORMANCE						
Sensitivity Error	E_{SENS}	$I_{\text{PR}} = \pm 50\text{A}$, $T_A = 25^{\circ}\text{C}$	-1.5	± 0.5	+1.5	%
		$I_{\text{PR}} = \pm 50\text{A}$, $T_A = 25 \sim 125^{\circ}\text{C}$	-2.5	± 2	+2.5	%
		$I_{\text{PR}} = \pm 50\text{A}$, $T_A = -40 \sim 25^{\circ}\text{C}$	-2.5	± 2	+2.5	%
Single output zero error	E_{VOQ}	IP=0A, $T_A = 25^{\circ}\text{C}$	-10	± 5	+10	mV
		IP=0A, $T_A = 25 \sim 125^{\circ}\text{C}$	-20	± 10	+20	mV
		IP=0A, $T_A = -40 \sim 25^{\circ}\text{C}$	-20	± 10	+20	mV
Differential Output zero Error	E_{VOE}	IP=0A, $T_A = 25^{\circ}\text{C}$	-10	± 5	+10	mV
		IP=0A, $T_A = 25 \sim 125^{\circ}\text{C}$	-20	± 10	+20	mV
		IP=0A, $T_A = -40 \sim 25^{\circ}\text{C}$	-20	± 10	+20	mV
TOTAL OUTPUT ERROR COMPONENTS: $E_{\text{TOT}} = \{[V_{\text{IOUT_ideal}}(I_{\text{PR}}) - V_{\text{IOUT}}(I_{\text{PR}})] / [\text{Sens}_{\text{ideal}} * I_{\text{PR}}]\} * 100\%$						
Total Output Error	E_{TOT}	$I_{\text{PR}} = \pm 50\text{A}$, $T_A = 25^{\circ}\text{C}$	-1.5	± 1	+1.5	%
		$I_{\text{PR}} = \pm 50\text{A}$, $T_A = 25^{\circ}\text{C} \sim 125^{\circ}\text{C}$	-2.5	± 2	+2.5	%
		$I_{\text{PR}} = \pm 50\text{A}$, $T_A = -40^{\circ}\text{C} \sim 25^{\circ}\text{C}$	-2.5	± 2	+2.5	%
Accuracy of overcurrent fault threshold						
Fast fault output	$E_{\text{IFLAG_F}}$	$T_A = 25^{\circ}\text{C}$		± 15		%
		$T_A = -40^{\circ}\text{C} \sim 125^{\circ}\text{C}$		± 25		%
Slow fault output	$E_{\text{IFLAG_S}}$	Max= $I_{\text{PR}} * 2$, $T_A = 25^{\circ}\text{C}$		± 15		%
		Max= $I_{\text{PR}} * 2$, $T_A = -40^{\circ}\text{C} \sim 125^{\circ}\text{C}$		± 25		%

[1] The typical value is +/-1 sigma, and 68.27% of products fall within this range; The maximum/minimum value is +/-3 sigma value, and 99.73% of products fall within this range

[2] For details about the relationship between the IFLAG_S overcurrent trigger threshold and OC_SET, see "The Relationship between OC_SET Pins and FLAG_S".

High Accuracy Current Sensor with Pin-Selectable Gains and Adjustable Overcurrent Fault Detection

SC824DFT-65F5 Individual Performance Characteristics

Note: Over full range of $T_A=25^{\circ}\text{C}$, $C_{\text{Bypass}}=0.47\mu\text{F}$, $C_{\text{Load}}=1\text{nF}$, $V_{\text{CC}}=5\text{V}$

Parameter	Symbol	Test Conditions	Min	Typ ^[1]	Max	Unit
NOMINAL PERFORMANCE (Regardless of life time drift error)						
Current-Sensing Range	I_{PR}		-65		65	A
IP=0A, VIOUT output voltage	V_{OQ}	IP=0A		2.5		V
VREF output voltage	V_{ref}	Independent of the IP input current		2.5		V
Sensitivity	Sens	$-65\text{A} < \text{IP} < 65\text{A}$		30.75		mV/A
Fast overcurrent threshold range	IFLAG_F	Built-in Overcurrent Threshold (Built-in 10)		81.25		A
Low speed overflow threshold range ^[2]	IFLAG_S	Min= $I_{\text{PR}} * 0.75$, Max= $I_{\text{PR}} * 2$,	48.75		130	A
ACCURACY PERFORMANCE						
Sensitivity Error	E_{SENS}	$I_{\text{PR}} = \pm 65\text{A}$, $T_A = 25^{\circ}\text{C}$	-1.5	± 0.5	+1.5	%
		$I_{\text{PR}} = \pm 65\text{A}$, $T_A = 25\sim 125^{\circ}\text{C}$	-2.5	± 2	+2.5	%
		$I_{\text{PR}} = \pm 65\text{A}$, $T_A = -40\sim 25^{\circ}\text{C}$	-2.5	± 2	+2.5	%
Single output zero error	E_{VOQ}	IP=0A, $T_A = 25^{\circ}\text{C}$	-10	± 5	+10	mV
		IP=0A, $T_A = 25\sim 125^{\circ}\text{C}$	-20	± 10	+20	mV
		IP=0A, $T_A = -40\sim 25^{\circ}\text{C}$	-20	± 10	+20	mV
Differential Output zero Error	E_{VOE}	IP=0A, $T_A = 25^{\circ}\text{C}$	-10	± 5	+10	mV
		IP=0A, $T_A = 25\sim 125^{\circ}\text{C}$	-20	± 10	+20	mV
		IP=0A, $T_A = -40\sim 25^{\circ}\text{C}$	-20	± 10	+20	mV
TOTAL OUTPUT ERROR COMPONENTS: $E_{\text{TOT}} = \{[V_{\text{IOUT_ideal}}(I_{\text{PR}}) - V_{\text{IOUT}}(I_{\text{PR}})]/[Sens_{\text{Ideal}} * I_{\text{PR}}]\} * 100\%$						
Total Output Error	E_{TOT}	$I_{\text{PR}} = \pm 65\text{A}$, $T_A = 25^{\circ}\text{C}$	-1.5	± 1	+1.5	%
		$I_{\text{PR}} = \pm 65\text{A}$, $T_A = 25^{\circ}\text{C} \sim 125^{\circ}\text{C}$	-2.5	± 2	+2.5	%
		$I_{\text{PR}} = \pm 65\text{A}$, $T_A = -40^{\circ}\text{C} \sim 25^{\circ}\text{C}$	-3	± 2.5	+3	%
Accuracy of overcurrent fault threshold						
Fast fault output	$E_{\text{IFLAG_F}}$	$T_A = 25^{\circ}\text{C}$		± 15		%
		$T_A = -40^{\circ}\text{C} \sim 125^{\circ}\text{C}$		± 25		%
Slow fault output	$E_{\text{IFLAG_S}}$	Max= $I_{\text{PR}} * 2$, $T_A = 25^{\circ}\text{C}$		± 15		%
		Max= $I_{\text{PR}} * 2$, $T_A = -40^{\circ}\text{C} \sim 125^{\circ}\text{C}$		± 25		%

[1] The typical value is +/-1 sigma, and 68.27% of products fall within this range; The maximum/minimum value is +/-3 sigma value, and 99.73% of products fall within this range

[2] For details about the relationship between the IFLAG_S overcurrent trigger threshold and OC_SET, see "The Relationship between OC_SET Pins and FLAG_S".

High Accuracy Current Sensor with Pin-Selectable Gains and Adjustable Overcurrent Fault Detection

SC824DFT-75F5 Individual Performance Characteristics

Note: Over full range of $T_A=25^{\circ}\text{C}$, $C_{\text{Bypass}}=0.47\mu\text{F}$, $C_{\text{Load}}=1\text{nF}$, $V_{\text{CC}}=5\text{V}$

Parameter	Symbol	Test Conditions	Min	Typ ^[1]	Max	Unit
NOMINAL PERFORMANCE (Regardless of life time drift error)						
Current-Sensing Range	I_{PR}		-75		75	A
IP=0A, V_{IOUT} output voltage	V_{OQ}	IP=0A		2.5		V
VREF output voltage	V_{ref}	Independent of the IP input current		2.5		V
Sensitivity	Sens	$-75\text{A} < \text{IP} < 75\text{A}$		26.66		mV/A
Fast overcurrent threshold range	IFLAG_F	Built-in Overcurrent Threshold (Built-in 10)		93.75		A
Low speed overflow threshold range ^[2]	IFLAG_S	Min= $I_{\text{PR}} * 0.75$, Max= $I_{\text{PR}} * 2$,	56.25		150	A
ACCURACY PERFORMANCE						
Sensitivity Error	E_{SENS}	$I_{\text{PR}} = \pm 75\text{A}$, $T_A = 25^{\circ}\text{C}$		± 1		%
		$I_{\text{PR}} = \pm 75\text{A}$, $T_A = 25\sim 125^{\circ}\text{C}$		± 2		%
		$I_{\text{PR}} = \pm 75\text{A}$, $T_A = -40\sim 25^{\circ}\text{C}$		± 2		%
Single output zero error	E_{VOQ}	IP=0A, $T_A = 25^{\circ}\text{C}$		± 10		mV
		IP=0A, $T_A = 25\sim 125^{\circ}\text{C}$		± 15		mV
		IP=0A, $T_A = -40\sim 25^{\circ}\text{C}$		± 15		mV
Differential Output zero Error	E_{VOE}	IP=0A, $T_A = 25^{\circ}\text{C}$		± 5		mV
		IP=0A, $T_A = 25\sim 125^{\circ}\text{C}$		± 10		mV
		IP=0A, $T_A = -40\sim 25^{\circ}\text{C}$		± 10		mV
TOTAL OUTPUT ERROR COMPONENTS: $E_{\text{TOT}} = \{[V_{\text{IOUT_ideal}}(I_{\text{PR}}) - V_{\text{IOUT}}(I_{\text{PR}})] / [\text{Sens}_{\text{ideal}} * I_{\text{PR}}]\} * 100\%$						
Total Output Error	E_{TOT}	$I_{\text{PR}} = \pm 75\text{A}$, $T_A = 25^{\circ}\text{C}$		± 1		%
		$I_{\text{PR}} = \pm 75\text{A}$, $T_A = 25^{\circ}\text{C} \sim 125^{\circ}\text{C}$		± 2		%
		$I_{\text{PR}} = \pm 75\text{A}$, $T_A = -40^{\circ}\text{C} \sim 25^{\circ}\text{C}$		± 2.5		%
Accuracy of overcurrent fault threshold						
Fast fault output	$E_{\text{IFLAG_F}}$	$T_A = 25^{\circ}\text{C}$		± 15		%
		$T_A = -40^{\circ}\text{C} \sim 125^{\circ}\text{C}$		± 25		%
Slow fault output	$E_{\text{IFLAG_S}}$	Max= $I_{\text{PR}} * 2$, $T_A = 25^{\circ}\text{C}$		± 15		%
		Max= $I_{\text{PR}} * 2$, $T_A = -40^{\circ}\text{C} \sim 125^{\circ}\text{C}$		± 25		%

[1] The typical value is +/-1 sigma, and 68.27% of products fall within this range; The maximum/minimum value is +/-3 sigma value, and 99.73% of products fall within this range

[2] For details about the relationship between the IFLAG_S overcurrent trigger threshold and OC_SET, see "The Relationship between OC_SET Pins and FLAG_S".

High Accuracy Current Sensor with Pin-Selectable Gains and Adjustable Overcurrent Fault Detection

SC825DFT-30F3 Individual Performance Characteristics

Note: Over full range of $T_A=25^{\circ}\text{C}$, $C_{\text{Bypass}}=0.47\mu\text{F}$, $C_{\text{Load}}=1\text{nF}$, $V_{\text{CC}}=3.3\text{V}$

Parameter	Symbol	Test Conditions	Min	Typ ^[1]	Max	Unit
NOMINAL PERFORMANCE (Regardless of life time drift error)						
Current-Sensing Range	I_{PR}		-30		30	A
$I_{\text{P}}=0\text{A}$, V_{IOUT} output voltage	V_{OQ}	$I_{\text{P}}=0\text{A}$		1.65		V
VREF output voltage	V_{ref}	Independent of the I_{P} input current		1.65		V
Sensitivity	Sens	$-30\text{A} < I_{\text{P}} < 30\text{A}$		44		mV/A
Fast overcurrent threshold range	IFLAG_F	Built-in Overcurrent Threshold (Built-in 10)		37.5		A
Low speed overflow threshold range ^[2]	IFLAG_S	Min= $I_{\text{PR}} * 0.75$, Max= $I_{\text{PR}} * 2$	22.5		60	A
ACCURACY PERFORMANCE						
Sensitivity Error	E_{SENS}	$I_{\text{PR}} = \pm 30\text{A}$, $T_A = 25^{\circ}\text{C}$		± 1		%
		$I_{\text{PR}} = \pm 30\text{A}$, $T_A = 25\sim 125^{\circ}\text{C}$		± 2		%
		$I_{\text{PR}} = \pm 30\text{A}$, $T_A = -40\sim 25^{\circ}\text{C}$		± 2		%
Single output zero error	E_{VOQ}	$I_{\text{P}}=0\text{A}$, $T_A = 25^{\circ}\text{C}$		± 10		mV
		$I_{\text{P}}=0\text{A}$, $T_A = 25\sim 125^{\circ}\text{C}$		± 15		mV
		$I_{\text{P}}=0\text{A}$, $T_A = -40\sim 25^{\circ}\text{C}$		± 15		mV
Differential Output zero Error	E_{VOE}	$I_{\text{P}}=0\text{A}$, $T_A = 25^{\circ}\text{C}$		± 5		mV
		$I_{\text{P}}=0\text{A}$, $T_A = 25\sim 125^{\circ}\text{C}$		± 10		mV
		$I_{\text{P}}=0\text{A}$, $T_A = -40\sim 25^{\circ}\text{C}$		± 10		mV
TOTAL OUTPUT ERROR COMPONENTS: $E_{\text{TOT}} = \{[V_{\text{IOUT_ideal}}(I_{\text{PR}}) - V_{\text{IOUT}}(I_{\text{PR}})] / [\text{Sens}_{\text{ideal}} * I_{\text{PR}}]\} * 100\%$						
Total Output Error	E_{TOT}	$I_{\text{PR}} = \pm 30\text{A}$, $T_A = 25^{\circ}\text{C}$		± 1		%
		$I_{\text{PR}} = \pm 30\text{A}$, $T_A = 25^{\circ}\text{C} \sim 125^{\circ}\text{C}$		± 2		%
		$I_{\text{PR}} = \pm 30\text{A}$, $T_A = -40^{\circ}\text{C} \sim 25^{\circ}\text{C}$		± 2		%
Accuracy of overcurrent fault threshold						
Fast fault output	$E_{\text{IFLAG_F}}$	$T_A = 25^{\circ}\text{C}$		± 15		%
		$T_A = -40^{\circ}\text{C} \sim 125^{\circ}\text{C}$		± 25		%
Slow fault output	$E_{\text{IFLAG_S}}$	Max= $I_{\text{PR}} * 2$, $T_A = 25^{\circ}\text{C}$		± 15		%
		Max= $I_{\text{PR}} * 2$, $T_A = -40^{\circ}\text{C} \sim 125^{\circ}\text{C}$		± 25		%

[1] The typical value is ± 1 sigma, and 68.27% of products fall within this range; The maximum/minimum value is ± 3 sigma value, and 99.73% of products fall within this range

[2] For details about the relationship between the IFLAG_S overcurrent trigger threshold and OC_SET, see "The Relationship between OC_SET Pins and FLAG_S".

High Accuracy Current Sensor with Pin-Selectable Gains and Adjustable Overcurrent Fault Detection

SC825DFT-50F3 Individual Performance Characteristics

Note: Over full range of $T_A=25^{\circ}\text{C}$, $C_{\text{Bypass}}=0.47\mu\text{F}$, $C_{\text{Load}}=1\text{nF}$, $V_{\text{CC}}=3.3\text{V}$

Parameter	Symbol	Test Conditions	Min	Typ ^[1]	Max	Unit
NOMINAL PERFORMANCE (Regardless of life time drift error)						
Current-Sensing Range	I_{PR}		-50		50	A
IP=0A, V_{IOUT} output voltage	V_{OQ}	IP=0A		1.65		V
VREF output voltage	V_{ref}	Independent of the IP input current		1.65		V
Sensitivity	Sens	$-50\text{A} < \text{IP} < 50\text{A}$		26.4		mV/A
Fast overcurrent threshold range	IFLAG_F	Built-in Overcurrent Threshold (Built-in 10)		62.5		A
Low speed overflow threshold range ^[2]	IFLAG_S	Min= $I_{\text{PR}} * 0.75$, Max= $I_{\text{PR}} * 2$,	37.5		100	A
ACCURACY PERFORMANCE						
Sensitivity Error	E_{SENS}	$I_{\text{PR}} = \pm 50\text{A}$, $T_A = 25^{\circ}\text{C}$		± 1		%
		$I_{\text{PR}} = \pm 50\text{A}$, $T_A = 25 \sim 125^{\circ}\text{C}$		± 2		%
		$I_{\text{PR}} = \pm 50\text{A}$, $T_A = -40 \sim 25^{\circ}\text{C}$		± 2		%
Single output zero error	E_{VOQ}	IP=0A, $T_A = 25^{\circ}\text{C}$		± 10		mV
		IP=0A, $T_A = 25 \sim 125^{\circ}\text{C}$		± 15		mV
		IP=0A, $T_A = -40 \sim 25^{\circ}\text{C}$		± 15		mV
Differential Output zero Error	E_{VOE}	IP=0A, $T_A = 25^{\circ}\text{C}$		± 5		mV
		IP=0A, $T_A = 25 \sim 125^{\circ}\text{C}$		± 10		mV
		IP=0A, $T_A = -40 \sim 25^{\circ}\text{C}$		± 10		mV
TOTAL OUTPUT ERROR COMPONENTS: $E_{\text{TOT}} = \{[V_{\text{IOUT_ideal}}(I_{\text{PR}}) - V_{\text{IOUT}}(I_{\text{PR}})] / [\text{Sens}_{\text{ideal}} * I_{\text{PR}}]\} * 100\%$						
Total Output Error	E_{TOT}	$I_{\text{PR}} = \pm 50\text{A}$, $T_A = 25^{\circ}\text{C}$		± 1		%
		$I_{\text{PR}} = \pm 50\text{A}$, $T_A = 25^{\circ}\text{C} \sim 125^{\circ}\text{C}$		± 2		%
		$I_{\text{PR}} = \pm 50\text{A}$, $T_A = -40^{\circ}\text{C} \sim 25^{\circ}\text{C}$		± 2		%
Accuracy of overcurrent fault threshold						
Fast fault output	$E_{\text{IFLAG_F}}$	$T_A = 25^{\circ}\text{C}$		± 15		%
		$T_A = -40^{\circ}\text{C} \sim 125^{\circ}\text{C}$		± 25		%
Slow fault output	$E_{\text{IFLAG_S}}$	Max= $I_{\text{PR}} * 2$, $T_A = 25^{\circ}\text{C}$		± 15		%
		Max= $I_{\text{PR}} * 2$, $T_A = -40^{\circ}\text{C} \sim 125^{\circ}\text{C}$		± 25		%

[1] The typical value is ± 1 sigma, and 68.27% of products fall within this range; The maximum/minimum value is ± 3 sigma value, and 99.73% of products fall within this range

[2] For details about the relationship between the IFLAG_S overcurrent trigger threshold and OC_SET, see "The Relationship between OC_SET Pins and FLAG_S".

High Accuracy Current Sensor with Pin-Selectable Gains and Adjustable Overcurrent Fault Detection

SC825DFT-80F3 Individual Performance Characteristics

Note: Over full range of $T_A=25^{\circ}\text{C}$, $C_{\text{Bypass}}=0.47\mu\text{F}$, $C_{\text{Load}}=1\text{nF}$, $V_{\text{CC}}=3.3\text{V}$

Parameter	Symbol	Test Conditions	Min	Typ ^[1]	Max	Unit
NOMINAL PERFORMANCE (Regardless of life time drift error)						
Current-Sensing Range	I_{PR}		-80		80	A
$I_{\text{P}}=0\text{A}$, $V_{\text{IOU}}\text{ output voltage}$	V_{OQ}	$I_{\text{P}}=0\text{A}$		1.65		V
VREF output voltage	V_{ref}	Independent of the IP input current		1.65		V
Sensitivity	Sens	$-80\text{A} < I_{\text{P}} < 80\text{A}$		16.5		mV/A
Fast overcurrent threshold range	IFLAG_F	Built-in Overcurrent Threshold (Built-in 10)		100		A
Low speed overflow threshold range ^[2]	IFLAG_S	$\text{Min}=I_{\text{PR}} * 0.75$, $\text{Max}=I_{\text{PR}} * 2$,	60		160	A
ACCURACY PERFORMANCE						
Sensitivity Error	E_{SENS}	$I_{\text{PR}} = \pm 80\text{A}$, $T_A = 25^{\circ}\text{C}$		± 1		%
		$I_{\text{PR}} = \pm 80\text{A}$, $T_A = 25 \sim 125^{\circ}\text{C}$		± 2		%
		$I_{\text{PR}} = \pm 80\text{A}$, $T_A = -40 \sim 25^{\circ}\text{C}$		± 2		%
Single output zero error	E_{VOQ}	$I_{\text{P}}=0\text{A}$, $T_A = 25^{\circ}\text{C}$		± 10		mV
		$I_{\text{P}}=0\text{A}$, $T_A = 25 \sim 125^{\circ}\text{C}$		± 15		mV
		$I_{\text{P}}=0\text{A}$, $T_A = -40 \sim 25^{\circ}\text{C}$		± 15		mV
Differential Output zero Error	E_{VOE}	$I_{\text{P}}=0\text{A}$, $T_A = 25^{\circ}\text{C}$		± 5		mV
		$I_{\text{P}}=0\text{A}$, $T_A = 25 \sim 125^{\circ}\text{C}$		± 10		mV
		$I_{\text{P}}=0\text{A}$, $T_A = -40 \sim 25^{\circ}\text{C}$		± 10		mV
TOTAL OUTPUT ERROR COMPONENTS: $E_{\text{TOT}} = \{[V_{\text{IOU}}_{\text{ideal}}(I_{\text{PR}}) - V_{\text{IOU}}(I_{\text{PR}})] / [\text{Sens}_{\text{ideal}} * I_{\text{PR}}]\} * 100\%$						
Total Output Error	E_{TOT}	$I_{\text{PR}} = \pm 80\text{A}$, $T_A = 25^{\circ}\text{C}$		± 1		%
		$I_{\text{PR}} = \pm 80\text{A}$, $T_A = 25^{\circ}\text{C} \sim 125^{\circ}\text{C}$		± 2		%
		$I_{\text{PR}} = \pm 80\text{A}$, $T_A = -40^{\circ}\text{C} \sim 25^{\circ}\text{C}$		± 2		%
Accuracy of overcurrent fault threshold						
Fast fault output	E_{IFLAG_F}	$T_A = 25^{\circ}\text{C}$		± 15		%
		$T_A = -40^{\circ}\text{C} \sim 125^{\circ}\text{C}$		± 25		%
Slow fault output	E_{IFLAG_S}	$\text{Max}=I_{\text{PR}} * 2$, $T_A = 25^{\circ}\text{C}$		± 15		%
		$\text{Max}=I_{\text{PR}} * 2$, $T_A = -40^{\circ}\text{C} \sim 125^{\circ}\text{C}$		± 25		%

[1] The typical value is +/-1 sigma, and 68.27% of products fall within this range; The maximum/minimum value is +/-3 sigma value, and 99.73% of products fall within this range

[2] For details about the relationship between the IFLAG_S overcurrent trigger threshold and OC_SET, see "The Relationship between OC_SET Pins and FLAG_S".

High Accuracy Current Sensor with Pin-Selectable Gains and Adjustable Overcurrent Fault Detection

SC825DFT-65U3 Individual Performance Characteristics

Note: Over full range of $T_A=25^{\circ}\text{C}$, $C_{\text{Bypass}}=0.47\mu\text{F}$, $C_{\text{Load}}=1\text{nF}$, $V_{\text{CC}}=3.3\text{V}$

Parameter	Symbol	Test Conditions	Min	Typ ^[1]	Max	Unit
NOMINAL PERFORMANCE (Regardless of life time drift error)						
Current-Sensing Range	I_{PR}		0		65	A
$I_{\text{P}}=0\text{A}$, V_{IOUT} output voltage	V_{OQ}	$I_{\text{P}}=0\text{A}$		$0.1V_{\text{CC}}$		V
VREF output voltage	V_{ref}	Independent of the IP input current		$0.1V_{\text{CC}}$		V
Sensitivity	Sens	$0\text{A}<I_{\text{P}}<65\text{A}$		40.61		mV/A
Fast overcurrent threshold range	IFLAG_F	Built-in Overcurrent Threshold (Built-in 10)		81.25		A
Low speed overflow threshold range ^[2]	IFLAG_S	$\text{Min}=I_{\text{PR}} * 0.75$, $\text{Max}= I_{\text{PR}} * 2$,	48.75		130	A
ACCURACY PERFORMANCE						
Sensitivity Error	E_{SENS}	$I_{\text{PR}} = +65\text{ A}$, $T_A = 25^{\circ}\text{C}$		± 1		%
		$I_{\text{PR}} = +65\text{ A}$, $T_A = 25\sim 125^{\circ}\text{C}$		± 2		%
		$I_{\text{PR}} = +65\text{ A}$, $T_A = 125^{\circ}\text{C}\sim 150^{\circ}\text{C}$		± 1.5		%
		$I_{\text{PR}} = +65\text{ A}$, $T_A = -40\sim 25^{\circ}\text{C}$		± 2		%
Single output zero error	E_{VOQ}	$I_{\text{P}}=0\text{A}$, $T_A = 25^{\circ}\text{C}$		± 10		mV
		$I_{\text{P}}=0\text{A}$, $T_A = 25\sim 125^{\circ}\text{C}$		± 15		mV
		$I_{\text{P}}=0\text{A}$, $T_A = 125^{\circ}\text{C}\sim 150^{\circ}\text{C}$		± 5		mV
		$I_{\text{P}}=0\text{A}$, $T_A = -40\sim 25^{\circ}\text{C}$		± 15		mV
Differential Output zero Error	E_{VOE}	$I_{\text{P}}=0\text{A}$, $T_A = 25^{\circ}\text{C}$		± 5		mV
		$I_{\text{P}}=0\text{A}$, $T_A = 25\sim 125^{\circ}\text{C}$		± 10		mV
		$I_{\text{P}}=0\text{A}$, $T_A = 125^{\circ}\text{C}\sim 150^{\circ}\text{C}$		± 5		mV
		$I_{\text{P}}=0\text{A}$, $T_A = -40\sim 25^{\circ}\text{C}$		± 10		mV
TOTAL OUTPUT ERROR COMPONENTS: $E_{\text{TOT}} = \{[V_{\text{IOUT_ideal}}(I_{\text{PR}}) - V_{\text{IOUT}}(I_{\text{PR}})]/[Sens_{\text{Ideal}} * I_{\text{PR}}]\} * 100\%$						
Total Output Error	E_{TOT}	$I_{\text{PR}} = +65\text{ A}$, $T_A = 25^{\circ}\text{C}$		± 1		%
		$I_{\text{PR}} = +65\text{ A}$, $T_A = 25\sim 125^{\circ}\text{C}$		± 2		%
		$I_{\text{PR}} = +65\text{ A}$, $T_A = 125^{\circ}\text{C}\sim 150^{\circ}\text{C}$		± 2		%
		$I_{\text{PR}} = +65\text{ A}$, $T_A = -40\sim 25^{\circ}\text{C}$		± 2		%
Accuracy of overcurrent fault threshold						
Fast fault output	$E_{\text{IFLAG_F}}$	$T_A=25^{\circ}\text{C}$		± 15		%
		$T_A=-40^{\circ}\text{C}\sim 125^{\circ}\text{C}$		± 25		%
Slow fault output	$E_{\text{IFLAG_S}}$	$\text{Max}=I_{\text{PR}} * 2$, $T_A=25^{\circ}\text{C}$		± 15		%
		$\text{Max}=I_{\text{PR}} * 2$, $T_A=-40^{\circ}\text{C}\sim 125^{\circ}\text{C}$		± 25		%

[1] The typical value is +/-1 sigma, and 68.27% of products fall within this range; The maximum/minimum value is +/-3 sigma value, and 99.73% of products fall within this range

[2] For details about the relationship between the IFLAG_S overcurrent trigger threshold and OC_SET, see "The Relationship between OC_SET Pins and FLAG_S".

High Accuracy Current Sensor with Pin-Selectable Gains and Adjustable Overcurrent Fault Detection

SC824EFT-40F5 Individual Performance Characteristics

Note: Over full range of $T_A=25^\circ\text{C}$, $C_{\text{Bypass}}=0.47\mu\text{F}$, $C_{\text{Load}}=1\text{nF}$, $V_{\text{CC}}=5\text{V}$

Parameter	Symbol	Test Conditions	Min	Typ ^[1]	Max	Unit
NOMINAL PERFORMANCE (Regardless of life time drift error)						
Current-Sensing Range	I_{PR}		-40		40	A
$I_{\text{P}}=0\text{A}$, V_{IOUT} output voltage	V_{OQ}	$I_{\text{P}}=0\text{A}$		2.5		V
Sensitivity	Sens	$-40\text{A}<I_{\text{P}}<40\text{A}$		50		mV/A
Low speed overflow threshold range ^[2]	IFLAG_S	Min= $I_{\text{PR}} * 0.75$, Max= $I_{\text{PR}} * 2$,	30		80	A
ACCURACY PERFORMANCE						
Sensitivity Error	E_{SENS}	$I_{\text{PR}} = \pm 40\text{A}$, $T_A = 25^\circ\text{C}$	-1.5	± 0.5	+1.5	%
		$I_{\text{PR}} = \pm 40\text{A}$, $T_A = 25\sim 125^\circ\text{C}$	-2.5	± 2	+2.5	%
		$I_{\text{PR}} = \pm 40\text{A}$, $T_A = -40\sim 25^\circ\text{C}$	-2.5	± 2	+2.5	%
Single output zero error	E_{VOQ}	$I_{\text{P}}=0\text{A}$, $T_A = 25^\circ\text{C}$	-10	± 5	+10	mV
		$I_{\text{P}}=0\text{A}$, $T_A = 25\sim 125^\circ\text{C}$	-20	± 10	+20	mV
		$I_{\text{P}}=0\text{A}$, $T_A = -40\sim 25^\circ\text{C}$	-20	± 10	+20	mV
TOTAL OUTPUT ERROR COMPONENTS: $E_{\text{TOT}} = \{[V_{\text{IOUT_ideal}}(I_{\text{PR}}) - V_{\text{IOUT}}(I_{\text{PR}})] / [\text{Sens}_{\text{ideal}} * I_{\text{PR}}]\} * 100\%$						
Total Output Error	E_{TOT}	$I_{\text{PR}} = \pm 40\text{A}$, $T_A = 25^\circ\text{C}$	-1.5	± 1	+1.5	%
		$I_{\text{PR}} = \pm 40\text{A}$, $T_A = 25^\circ\text{C} \sim 125^\circ\text{C}$	-2.5	± 2	+2.5	%
		$I_{\text{PR}} = \pm 40\text{A}$, $T_A = -40^\circ\text{C} \sim 25^\circ\text{C}$	-2.5	± 2	+2.5	%
Accuracy of overcurrent fault threshold						
Slow fault output	$E_{\text{IFLAG_S}}$	Max= $I_{\text{PR}} * 2$, $T_A = 25^\circ\text{C}$		± 15		%
		Max= $I_{\text{PR}} * 2$, $T_A = -40^\circ\text{C} \sim 125^\circ\text{C}$		± 25		%

[1] The typical value is ± 1 sigma, and 68.27% of products fall within this range; The maximum/minimum value is ± 3 sigma value, and 99.73% of products fall within this range

[2] For details about the relationship between the IFLAG_S overcurrent trigger threshold and OC_SET, see "The Relationship between OC_SET Pins and FLAG_S".

High Accuracy Current Sensor with Pin-Selectable Gains and Adjustable Overcurrent Fault Detection

SC824EFT-65F5 Individual Performance Characteristics

Note: Over full range of $T_A=25^{\circ}\text{C}$, $C_{\text{Bypass}}=0.47\mu\text{F}$, $C_{\text{Load}}=1\text{nF}$, $V_{\text{CC}}=5\text{V}$

Parameter	Symbol	Test Conditions	Min	Typ ^[1]	Max	Unit
NOMINAL PERFORMANCE (Regardless of life time drift error)						
Current-Sensing Range	I_{PR}		-65		65	A
$I_{\text{P}}=0\text{A}$, V_{IOUT} output voltage	V_{OQ}	$I_{\text{P}}=0\text{A}$		2.5		V
Sensitivity	Sens	$-65\text{A}<I_{\text{P}}<65\text{A}$		30.75		mV/A
Low speed overflow threshold range ^[2]	IFLAG_S	Min= $I_{\text{PR}} * 0.75$, Max= $I_{\text{PR}} * 2$,	48.75		130	A
ACCURACY PERFORMANCE						
Sensitivity Error	E_{SENS}	$I_{\text{PR}} = \pm 65\text{A}$, $T_A = 25^{\circ}\text{C}$	-1.5	± 0.5	+1.5	%
		$I_{\text{PR}} = \pm 65\text{A}$, $T_A = 25\sim 125^{\circ}\text{C}$	-2.5	± 2	+2.5	%
		$I_{\text{PR}} = \pm 65\text{A}$, $T_A = -40\sim 25^{\circ}\text{C}$	-2.5	± 2	+2.5	%
Single output zero error	E_{VOQ}	$I_{\text{P}}=0\text{A}$, $T_A = 25^{\circ}\text{C}$	-10	± 5	+10	mV
		$I_{\text{P}}=0\text{A}$, $T_A = 25\sim 125^{\circ}\text{C}$	-20	± 10	+20	mV
		$I_{\text{P}}=0\text{A}$, $T_A = -40\sim 25^{\circ}\text{C}$	-20	± 10	+20	mV
TOTAL OUTPUT ERROR COMPONENTS: $E_{\text{TOT}} = \{[V_{\text{IOUT_ideal}}(I_{\text{PR}}) - V_{\text{IOUT}}(I_{\text{PR}})] / [\text{Sens}_{\text{ideal}} * I_{\text{PR}}]\} * 100\%$						
Total Output Error	E_{TOT}	$I_{\text{PR}} = \pm 65\text{A}$, $T_A = 25^{\circ}\text{C}$	-1.5	± 1	+1.5	%
		$I_{\text{PR}} = \pm 65\text{A}$, $T_A = 25^{\circ}\text{C} \sim 125^{\circ}\text{C}$	-2.5	± 2	+2.5	%
		$I_{\text{PR}} = \pm 65\text{A}$, $T_A = -40^{\circ}\text{C} \sim 25^{\circ}\text{C}$	-2.5	± 2	+2.5	%
Accuracy of overcurrent fault threshold						
Slow fault output	$E_{\text{IFLAG_S}}$	Max= $I_{\text{PR}} * 2$, $T_A = 25^{\circ}\text{C}$		± 15		%
		Max= $I_{\text{PR}} * 2$, $T_A = -40^{\circ}\text{C} \sim 125^{\circ}\text{C}$		± 25		%

[1] The typical value is ± 1 sigma, and 68.27% of products fall within this range; The maximum/minimum value is ± 3 sigma value, and 99.73% of products fall within this range

[2] For details about the relationship between the IFLAG_S overcurrent trigger threshold and OC_SET, see "The Relationship between OC_SET Pins and FLAG_S".

High Accuracy Current Sensor with Pin-Selectable Gains and Adjustable Overcurrent Fault Detection

SC825EFT-20F3 Individual Performance Characteristics

Note: Over full range of $T_A=25^{\circ}\text{C}$, $C_{\text{Bypass}}=0.47\mu\text{F}$, $C_{\text{Load}}=1\text{nF}$, $V_{\text{CC}}=3.3\text{V}$

Parameter	Symbol	Test Conditions	Min	Typ ^[1]	Max	Unit
NOMINAL PERFORMANCE (Regardless of life time drift error)						
Current-Sensing Range	I_{PR}		-20		20	A
$I_{\text{P}}=0\text{A}$, V_{IOUT} output voltage	V_{OQ}	$I_{\text{P}}=0\text{A}$		1.65		V
Sensitivity	Sens	$-20\text{A}<I_{\text{P}}<20\text{A}$		66		mV/A
Low speed overflow threshold range ^[2]	IFLAG_S	Min= $I_{\text{PR}} * 0.75$, Max= $I_{\text{PR}} * 2$	15		40	A
ACCURACY PERFORMANCE						
Sensitivity Error	E_{SENS}	$I_{\text{PR}} = \pm 20\text{A}$, $T_A = 25^{\circ}\text{C}$		± 1		%
		$I_{\text{PR}} = \pm 20\text{A}$, $T_A = 25\sim 125^{\circ}\text{C}$		± 2		%
		$I_{\text{PR}} = \pm 20\text{A}$, $T_A = -40\sim 25^{\circ}\text{C}$		± 2		%
Single output zero error	E_{VOQ}	$I_{\text{P}}=0\text{A}$, $T_A = 25^{\circ}\text{C}$		± 5		mV
		$I_{\text{P}}=0\text{A}$, $T_A = 25\sim 125^{\circ}\text{C}$		± 10		mV
		$I_{\text{P}}=0\text{A}$, $T_A = -40\sim 25^{\circ}\text{C}$		± 10		mV
TOTAL OUTPUT ERROR COMPONENTS: $E_{\text{TOT}} = \{[V_{\text{IOUT_ideal}}(I_{\text{PR}}) - V_{\text{IOUT}}(I_{\text{PR}})] / [\text{Sens}_{\text{ideal}} * I_{\text{PR}}]\} * 100\%$						
Total Output Error	E_{TOT}	$I_{\text{PR}} = \pm 20\text{A}$, $T_A=25^{\circ}\text{C}$		± 1		%
		$I_{\text{PR}} = \pm 20\text{A}$, $T_A=25^{\circ}\text{C}\sim 125^{\circ}\text{C}$		± 2		%
		$I_{\text{PR}} = \pm 20\text{A}$, $T_A= -40^{\circ}\text{C} \sim 25^{\circ}\text{C}$		± 2		%
Accuracy of overcurrent fault threshold						
Slow fault output	$E_{\text{IFLAG_S}}$	Max= $I_{\text{PR}} * 2$, $T_A=25^{\circ}\text{C}$		± 15		%
		Max= $I_{\text{PR}} * 2$, $T_A=-40^{\circ}\text{C}\sim 125^{\circ}\text{C}$		± 25		%

[1] The typical value is ± 1 sigma, and 68.27% of products fall within this range; The maximum/minimum value is ± 3 sigma value, and 99.73% of products fall within this range

[2] For details about the relationship between the IFLAG_S overcurrent trigger threshold and OC_SET, see "The Relationship between OC_SET Pins and FLAG_S".

High Accuracy Current Sensor with Pin-Selectable Gains and Adjustable Overcurrent Fault Detection

SC825EFT-40F3 Individual Performance Characteristics

Note: Over full range of $T_A=25^{\circ}\text{C}$, $C_{\text{Bypass}}=0.47\mu\text{F}$, $C_{\text{Load}}=1\text{nF}$, $V_{\text{CC}}=3.3\text{V}$

Parameter	Symbol	Test Conditions	Min	Typ ^[1]	Max	Unit
NOMINAL PERFORMANCE (Regardless of life time drift error)						
Current-Sensing Range	I_{PR}		-40		40	A
$I_{\text{P}}=0\text{A}$, V_{IOUT} output voltage	V_{OQ}	$I_{\text{P}}=0\text{A}$		1.65		V
Sensitivity	Sens	$-40\text{A}<I_{\text{P}}<40\text{A}$		33		mV/A
Low speed overflow threshold range ^[2]	IFLAG_S	Min= $I_{\text{PR}} * 0.75$, Max= $I_{\text{PR}} * 2$	30		80	A
ACCURACY PERFORMANCE						
Sensitivity Error	E_{SENS}	$I_{\text{PR}} = \pm 40\text{A}$, $T_A = 25^{\circ}\text{C}$	-1.5	± 1	+1.5	%
		$I_{\text{PR}} = \pm 40\text{A}$, $T_A = 25\sim 125^{\circ}\text{C}$	-2.5	± 2	+2.5	%
		$I_{\text{PR}} = \pm 40\text{A}$, $T_A = -40\sim 25^{\circ}\text{C}$	-2.5	± 2	+2.5	%
Single output zero error	E_{VOQ}	$I_{\text{P}}=0\text{A}$, $T_A = 25^{\circ}\text{C}$	-10	± 5	+10	mV
		$I_{\text{P}}=0\text{A}$, $T_A = 25\sim 125^{\circ}\text{C}$	-20	± 10	+20	mV
		$I_{\text{P}}=0\text{A}$, $T_A = -40\sim 25^{\circ}\text{C}$	-20	± 10	+20	mV
TOTAL OUTPUT ERROR COMPONENTS: $E_{\text{TOT}} = \{[V_{\text{IOUT_ideal}}(I_{\text{PR}}) - V_{\text{IOUT}}(I_{\text{PR}})] / [\text{Sens}_{\text{ideal}} * I_{\text{PR}}]\} * 100\%$						
Total Output Error	E_{TOT}	$I_{\text{PR}} = \pm 40\text{A}$, $T_A = 25^{\circ}\text{C}$	-1.5	± 1	+1.5	%
		$I_{\text{PR}} = \pm 40\text{A}$, $T_A = 25^{\circ}\text{C} \sim 125^{\circ}\text{C}$	-2.5	± 2	+2.5	%
		$I_{\text{PR}} = \pm 40\text{A}$, $T_A = -40^{\circ}\text{C} \sim 25^{\circ}\text{C}$	-2.5	± 2	+2.5	%
Accuracy of overcurrent fault threshold						
Slow fault output	$E_{\text{IFLAG_S}}$	Max= $I_{\text{PR}} * 2$, $T_A = 25^{\circ}\text{C}$		± 15		%
		Max= $I_{\text{PR}} * 2$, $T_A = -40^{\circ}\text{C} \sim 125^{\circ}\text{C}$		± 25		%

[1] The typical value is ± 1 sigma, and 68.27% of products fall within this range; The maximum/minimum value is ± 3 sigma value, and 99.73% of products fall within this range

[2] For details about the relationship between the IFLAG_S overcurrent trigger threshold and OC_SET, see "The Relationship between OC_SET Pins and FLAG_S".

High Accuracy Current Sensor with Pin-Selectable Gains and Adjustable Overcurrent Fault Detection

SC825EFT-65F3 Individual Performance Characteristics

Note: Over full range of $T_A=25^{\circ}\text{C}$, $C_{\text{Bypass}}=0.47\mu\text{F}$, $C_{\text{Load}}=1\text{nF}$, $V_{\text{CC}}=3.3\text{V}$

Parameter	Symbol	Test Conditions	Min	Typ ^[1]	Max	Unit
NOMINAL PERFORMANCE (Regardless of life time drift error)						
Current-Sensing Range	I_{PR}		-65		65	A
$I_{\text{P}}=0\text{A}$, V_{IOUT} output voltage	V_{OQ}	$I_{\text{P}}=0\text{A}$		1.65		V
Sensitivity	Sens	$-65\text{A}<I_{\text{P}}<65\text{A}$		20		mV/A
Low speed overflow threshold range ^[2]	IFLAG_S	Min= $I_{\text{PR}} * 0.75$, Max= $I_{\text{PR}} * 2$	48.75		130	A
ACCURACY PERFORMANCE						
Sensitivity Error	E_{SENS}	$I_{\text{PR}} = \pm 65\text{A}$, $T_A = 25^{\circ}\text{C}$	-1.5	± 0.5	+1.5	%
		$I_{\text{PR}} = \pm 65\text{A}$, $T_A = 25\sim 125^{\circ}\text{C}$	-2.5	± 2	+2.5	%
		$I_{\text{PR}} = \pm 65\text{A}$, $T_A = -40\sim 25^{\circ}\text{C}$	-2.5	± 2	+2.5	%
Single output zero error	E_{VOQ}	$I_{\text{P}}=0\text{A}$, $T_A = 25^{\circ}\text{C}$	-10	± 5	+10	mV
		$I_{\text{P}}=0\text{A}$, $T_A = 25\sim 125^{\circ}\text{C}$	-20	± 10	+20	mV
		$I_{\text{P}}=0\text{A}$, $T_A = -40\sim 25^{\circ}\text{C}$	-20	± 10	+20	mV
TOTAL OUTPUT ERROR COMPONENTS: $E_{\text{TOT}} = \{[V_{\text{IOUT_ideal}}(I_{\text{PR}}) - V_{\text{IOUT}}(I_{\text{PR}})] / [\text{Sens}_{\text{ideal}} * I_{\text{PR}}]\} * 100\%$						
Total Output Error	E_{TOT}	$I_{\text{PR}} = \pm 65\text{A}$, $T_A = 25^{\circ}\text{C}$	-1.5	± 1	+1.5	%
		$I_{\text{PR}} = \pm 65\text{A}$, $T_A = 25^{\circ}\text{C} \sim 125^{\circ}\text{C}$	-2.5	± 2	+2.5	%
		$I_{\text{PR}} = \pm 65\text{A}$, $T_A = -40^{\circ}\text{C} \sim 25^{\circ}\text{C}$	-2.5	± 2	+2.5	%
Accuracy of overcurrent fault threshold						
Slow fault output	$E_{\text{IFLAG_S}}$	Max= $I_{\text{PR}} * 2$, $T_A = 25^{\circ}\text{C}$		± 15		%
		Max= $I_{\text{PR}} * 2$, $T_A = -40^{\circ}\text{C} \sim 125^{\circ}\text{C}$		± 25		%

[1] The typical value is ± 1 sigma, and 68.27% of products fall within this range; The maximum/minimum value is ± 3 sigma value, and 99.73% of products fall within this range

[2] For details about the relationship between the IFLAG_S overcurrent trigger threshold and OC_SET, see "The Relationship between OC_SET Pins and FLAG_S".

High Accuracy Current Sensor with Pin-Selectable Gains and Adjustable Overcurrent Fault Detection

SC825EFT-30U3 Individual Performance Characteristics

Note: Over full range of $T_A=25^{\circ}\text{C}$, $C_{\text{Bypass}}=0.47\mu\text{F}$, $C_{\text{Load}}=1\text{nF}$, $V_{\text{CC}}=3.3\text{V}$

Parameter	Symbol	Test Conditions	Min	Typ ^[1]	Max	Unit
NOMINAL PERFORMANCE (Regardless of life time drift error)						
Current-Sensing Range	I_{PR}		0		30	A
$I_{\text{P}}=0\text{A}$, V_{IOUT} output voltage	V_{OQ}	$I_{\text{P}}=0\text{A}$		$0.1V_{\text{CC}}$		V
Sensitivity	Sens	$0\text{A}<I_{\text{P}}<30\text{A}$		88		mV/A
Low speed overflow threshold range ^[2]	IFLAG_S	Min= $I_{\text{PR}} * 0.75$, Max= $I_{\text{PR}} * 2$	22.5		60	A
ACCURACY PERFORMANCE						
Sensitivity Error	E_{SENS}	$I_{\text{PR}} = +30\text{A}$, $T_A = 25^{\circ}\text{C}$	-1.5	± 0.5	+1.5	%
		$I_{\text{PR}} = +30\text{A}$, $T_A = 25\sim 125^{\circ}\text{C}$	-2.5	± 2	+2.5	%
		$I_{\text{PR}} = +30\text{A}$, $T_A = -40\sim 25^{\circ}\text{C}$	-2.5	± 2	+2.5	%
Single output zero error	E_{VOQ}	$I_{\text{P}}=0\text{A}$, $T_A = 25^{\circ}\text{C}$	-10	± 5	+10	mV
		$I_{\text{P}}=0\text{A}$, $T_A = 25\sim 125^{\circ}\text{C}$	-20	± 10	+20	mV
		$I_{\text{P}}=0\text{A}$, $T_A = -40\sim 25^{\circ}\text{C}$	-20	± 10	+20	mV
TOTAL OUTPUT ERROR COMPONENTS: $E_{\text{TOT}} = \{[V_{\text{IOUT_ideal}}(I_{\text{PR}}) - V_{\text{IOUT}}(I_{\text{PR}})] / [\text{Sens}_{\text{ideal}} * I_{\text{PR}}]\} * 100\%$						
Total Output Error	E_{TOT}	$I_{\text{PR}} = +30\text{A}$, $T_A = 25^{\circ}\text{C}$	-1.5	± 1	+1.5	%
		$I_{\text{PR}} = +30\text{A}$, $T_A = 25^{\circ}\text{C} \sim 125^{\circ}\text{C}$	-2.5	± 2	+2.5	%
		$I_{\text{PR}} = +30\text{A}$, $T_A = -40^{\circ}\text{C} \sim 25^{\circ}\text{C}$	-2.5	± 2	+2.5	%
Accuracy of overcurrent fault threshold						
Slow fault output	$E_{\text{IFLAG_S}}$	Max= $I_{\text{PR}} * 2$, $T_A = 25^{\circ}\text{C}$		± 15		%
		Max= $I_{\text{PR}} * 2$, $T_A = -40^{\circ}\text{C} \sim 125^{\circ}\text{C}$		± 25		%

[1] The typical value is +/-1 sigma, and 68.27% of products fall within this range; The maximum/minimum value is +/-3 sigma value, and 99.73% of products fall within this range

[2] For details about the relationship between the IFLAG_S overcurrent trigger threshold and OC_SET, see "The Relationship between OC_SET Pins and FLAG_S".

High Accuracy Current Sensor with Pin-Selectable Gains and Adjustable Overcurrent Fault Detection

Accuracy Characteristic Curve (SC824BFT-35G5)

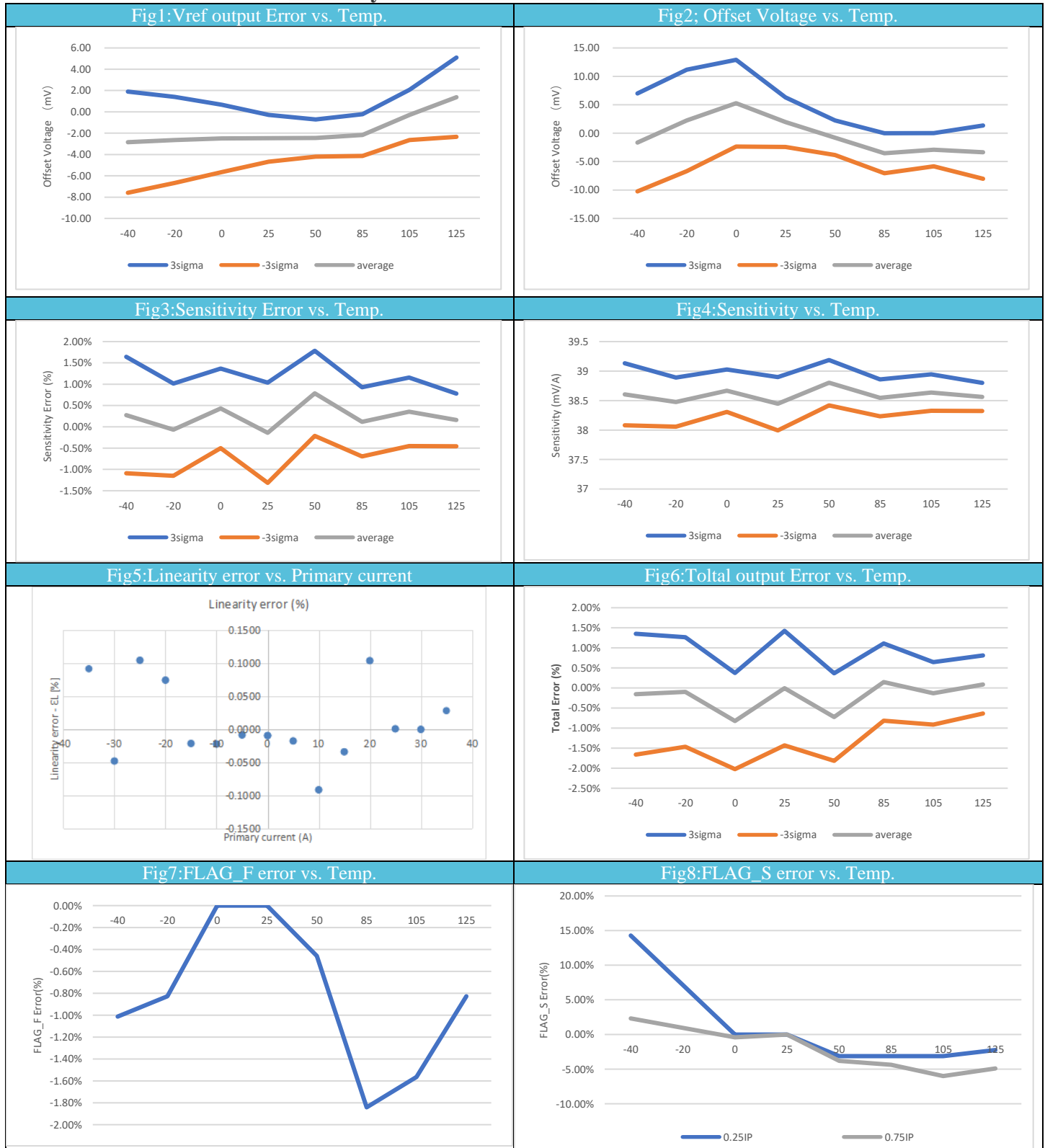

High Accuracy Current Sensor with Pin-Selectable Gains and Adjustable Overcurrent Fault Detection

AC/Dynamic characteristic diagram

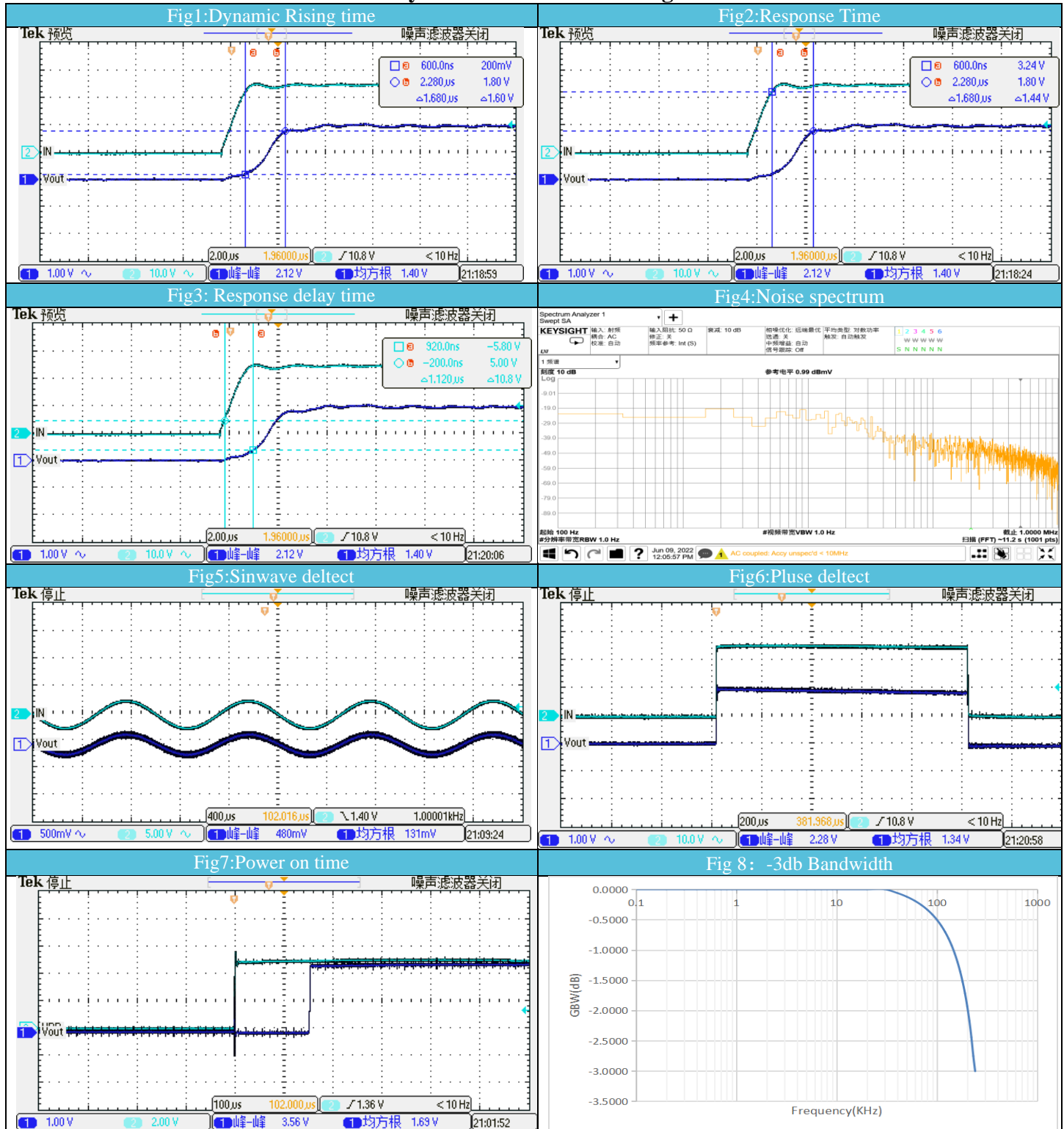

High Accuracy Current Sensor with Pin-Selectable Gains and Adjustable Overcurrent Fault Detection

Functional Description

Internal Reference Voltage

Vref is always equal to the static bias output value of VIOUT, that is, VIOUT value when IP=0A.

The relationship between VIOUT and Vref obey that following formula:

$$VIOUT = IP * Sens + Vref,$$

When using the SC82**FT**Fx, the VREF constant output is fixed at 2.5v and has a drive capability of 15mA;

When using the SC82**FT**Gx, the VREF constant output is fixed at 1.5v and has a drive capability of 15mA;

When using SC82**FT**Bx, the VREF output is 0.5VCC and has a drive capability of 15mA;

When using SC82**FT**Ux, the VREF output is 0.1VCC and has a drive capability of 15mA;

◆ Overcurrent Function

Description:

With two overcurrent fault comparators:

FLAG_F: When FLAG_F pins are pulled up, the default output is high. When the absolute value of the input current exceeds IPR* multiple, the comparator tripping output is pulled down to low level. This function has a <2uS ultra-fast response time, which is very suitable for detection and verification of short circuit events. The overcurrent must be maintained at least 1uS in order to be detected, and after the detection of the post stage, the output low signal will maintain a residence time of 10uS, so that the controller can easily detect the overcurrent signal.

FLAG_S: After FLAG_S pin is pulled up, the default output is high. When the absolute value of the input current exceeds the set threshold, the comparator tripping output is pulled down to the low level. This function improves the high precision characteristic and is suitable for the detection of overload conditions beyond the range. The overcurrent must be maintained at least 3uS in order to be detected, and after the detection of the post stage, the output low signal will maintain a residence time of 10uS, so that the controller can easily detect the overcurrent signal.

OC_SET: Allows users to set the FLAG_S trip threshold through external voltage dividers. The relationship between OC_SET pins and FLAG_S is shown in the following table:

OC_SET

PIN and FLAG_S Relationship

OC_SET input voltage ^[1]	IFLAG_S trigger threshold ^[2]					
	SC82xxxx-xxFx	SC82xxxx-xxBx	SC82xxxx-xxUx	SC82xxxx-xxIx	SC82xxxx-xxGx	
VCC=3.3 and 5V						
OC_SET ∈ (0.3*Vcc, 0.34*Vcc)	IPR*0.75				2/Sens*0.75	A
OC_SET ∈ (0.41*Vcc, 0.45*Vcc)	IPR*1				2/Sens*1	A
OC_SET ∈ (0.55*Vcc, 0.59*Vcc)	IPR*1.25				2/Sens*1.25	A
OC_SET ∈ (0.65*Vcc, 0.71*Vcc)	IPR*1.5				2/Sens*1.5	A
OC_SET ∈ (0.79*Vcc, 0.83*Vcc)	IPR*1.75				2/Sens*1.75	A
OC_SET ∈ (0.91*Vcc, 0.97*Vcc)	IPR*2				2/Sens*2	A

High Accuracy Current Sensor with Pin-Selectable Gains and Adjustable Overcurrent Fault Detection

[1] OC_SET function:

- 1) OC_SET input voltage supports $0.3 \cdot V_{CC} \sim 0.97 \cdot V_{CC}$ range, users can set the overcurrent alarm threshold of FLAG_S pin through the OC_SET input voltage (as shown in the above table), the input voltage is allowed to use VCC and resistance partial voltage for adaptive (Figure 1). When the OC_SET input voltage is in the range of $OC_SET \in (0.3 \cdot V_{CC}, 0.34 \cdot V_{CC})$, it corresponds to the minimum trigger point IFLAG; when the OC_SET input voltage is in the range of $OC_SET \in (0.91 \cdot V_{CC}, 0.97 \cdot V_{CC})$, it corresponds to the maximum trigger point IFLAG.
- 2) OC_SET input voltage supports $0.3 \cdot V_{CC} \sim 0.97 \cdot V_{CC}$ range, but it should be noted that it is not a linear selection, but designed into a STEP mode, set into 6 intervals, each interval has an input voltage range to correspond to the IFLAG overcurrent trigger threshold.

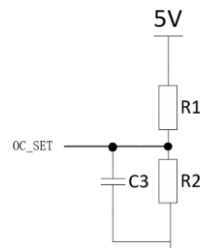

Figure 1: OC SET resistor divider

[2] Fixed IFLAG definition for 1.5v series:

When the user selects the SC824xxx-xxxGx, the 1.5V output model is fixed that the IFLAG overcurrent trigger threshold can be determined by the following formula::

$$IFLAG = \frac{2V}{Sensitivity} * Threshold\ multiple$$

[3] IFLAG trigger threshold:

Whether FLAG_S or FLAG_F sets the trigger threshold current, it is recommended that the actual loaded effective current is $IFLAG * 1.15$

High Accuracy Current Sensor with Pin-Selectable Gains and Adjustable Overcurrent Fault Detection

FLAG output characteristic diagram:

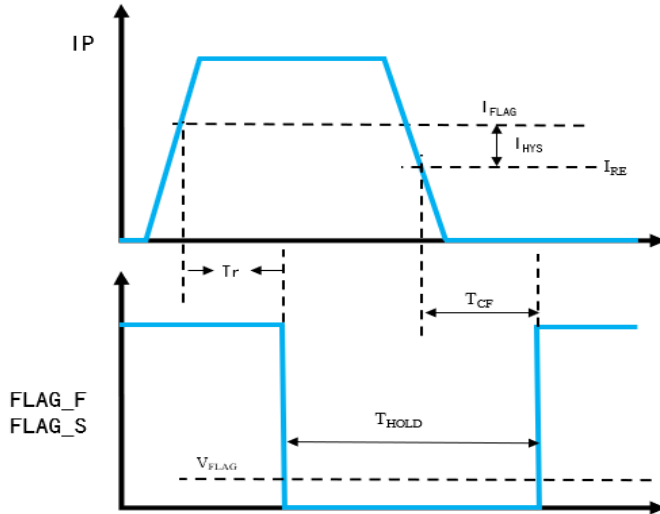

Figure 2: Fault response timing when the Tmask function is disabled

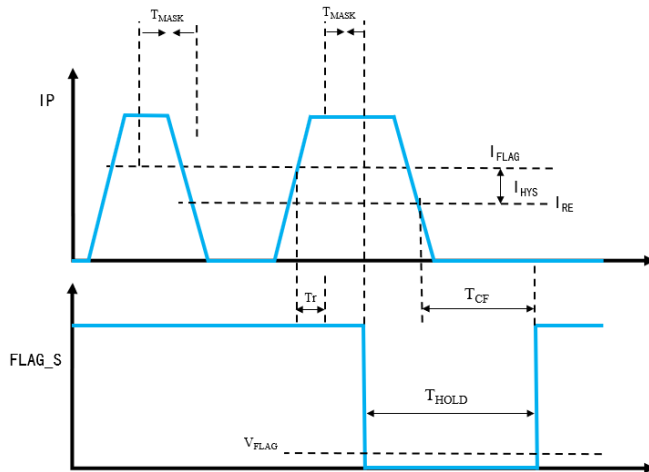

Figure 3: FLAG S timing diagram when Tmask function is enabled

Figure 2 The fault feature applies to FLAG_F as well as to FLAG_S, which is disabled by Tmask

When the current through the IP exceeds the IFLAG threshold, after the T_r delay time, the FLAG_F fault pin will trip, and the fault will remain active for a period of time until the absolute current is less than the fault threshold (IRE).

Figure 3 Fault characteristics apply to FLAG S when the Tmask function is enabled

TMASK is defined as the extra time that the primary side current must be present after the T_r time has passed. As shown in Figure 3, where the width of the first current transient pulse is smaller than TMASK, the purpose is that if a fault occurs, but the fault duration is smaller than TMASK, the device will not report the fault, which can prevent the wrong alarm caused by the interference signal of the transient current pulse.

When the second current pulse exceeds the IFLAG threshold and after a time of $\geq TMASK$, the fault is triggered and the output is pulled down, until the absolute current is less than the fault threshold (IRE), the fault will remain active for a period of time until the fault state is over and reset.

High Accuracy Current Sensor with Pin-Selectable Gains and Adjustable Overcurrent Fault Detection

Gain Selection Applications:

Note: GAIN=0: can be pulled down to Gnd or connected to the pull-down resistor; GAIN=1, which can be pulled up to VCC or NC for suspension processing.

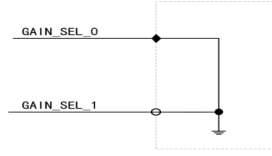
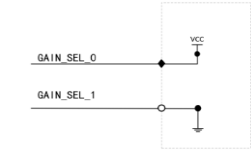
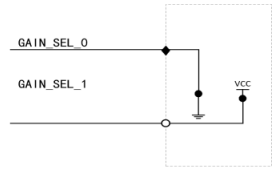
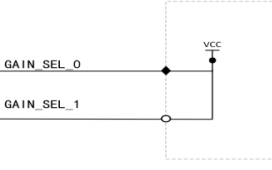
	GAIN_SEL_1 (Digital inputs)	GAIN_SEL_0 (Digital inputs)	应用选择	Gain relationships
Gain combinations	0	0		X1
	0	1		X2
	1	0		X4
	1	1		X1 or X8 (It is specified by model number)

High Accuracy Current Sensor with Pin-Selectable Gains and Adjustable Overcurrent Fault Detection

◆ Proportional Coefficient Of Sensitivity(Applies to products with the suffixes B and U)

Sensitivity ratio coefficient (sens_coef), which defines the coefficient proportional to the sensitivity and VCC. The ideal coefficient is 1. If the VCC increases by 10%, the sensitivity will increase by 10%. At this time, the coefficient is 1.1, which means that the sensitivity increases by 10% compared with the ideal proportion. The relationship between the scale coefficient is described by the following equation:

$$S_{coef} = \text{Sens_coef} = \text{SENS}_{VCC} / \text{SENS}_{VCCN}$$

It is the ratio of the sensitivity SENS_{VCC} under the supply voltage V_{cc} to the sensitivity SENS_{VCCN} under the rated supply voltage V_{CCN} . Through this value, we can get the sensitivity under any supply voltage.

In ideal situation:

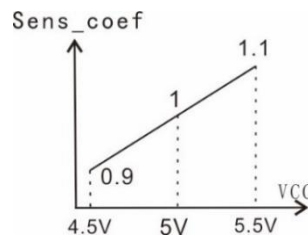

◆ Proportional Relationship

Using SC82**FT**F*, neither the zero voltage nor the sensitivity change with the VCC ratio, where the zero and sensitivity are constant.

Using SC82**FT**B*, sensitivity and zero voltage are changing with VCC proportion, zero for the $V_{CC} / 2$, sensitivity to $\text{SENS}_{VCC} * \text{Sens_coef}$.

Using SC82**FT**U*, sensitivity and zero voltage are changing with VCC proportion, zero for the $0.1V_{CC}$, sensitivity to $\text{SENS}_{VCC} * \text{Sens_coef}$.

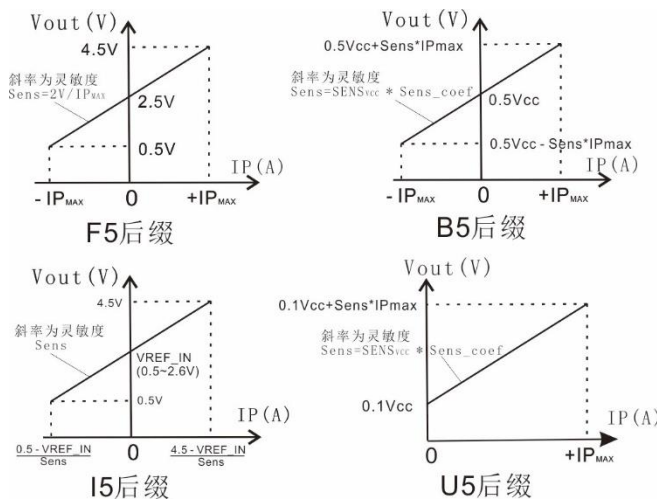

◆ Impact of External Magnetic Fields

CMFR is used to express the ability of sensor resisting impact of external magnetic fields. The larger the absolute value of CMFR, the stronger the ability to resist external magnetic interference is.

$$CMFR = 20 \lg \left| \frac{A_{CM}}{\text{Sens}/CF} \right|$$

Where CF is the magnetic field coupling factor of the primary current in the sensor, Sens is the sensor sensitivity, and Sens/CF represents the change ratio of the sensor itself in mv/G.

For example: CMFR= -40dB, Sens= 40mv/A, CF = 10G/A, then ACM is 0.04mv/G.

High Accuracy Current Sensor with Pin-Selectable Gains and Adjustable Overcurrent Fault Detection

◆ Power Rejection Ratio (for products with the suffix F)

The PSRR_S is the sensitivity change rate (SENS_{VCC}-SENS_{VCCN})/SENS_{VCCN} due to the power supply change ratio (VCC-VCC_N)/VCC_N, and the absolute value of the ratio is 20 times the commonly, used logarithm in decibels (dB).

$$PSRR_S = 20 \lg \left| \frac{(VCC - VCC_N)/VCC_N}{(SENS_{VCC} - SENS_{VCCN})/SENS_{VCCN}} \right|$$

For example, when the VCC of a power supply changes from 5V to 4.75V (i.e., a change of -5%), the sensitivity changes from 100mV/A to 99.95mV/A (i.e., a change of -0.05%)

$$PSRR_S = 20 \lg \left| \frac{-5\%}{-0.05\%} \right| = 40\text{dB}$$

The zero-point power supply rejection ratio (PSRR_Q) represents the zero-point change VOE-VOE_N caused by the change of the power supply VCC-VCC_N, and the absolute value of the ratio between the two is 20 times the commonly, used logarithm in decibels (dB).

$$PSRR_Q = 20 \lg \left| \frac{VCC - VCC_N}{VOE - VOE_N} \right|$$

For example, if the VCC of a model changes from 5V to 4.75V (change by 250mV), the zero point changes from 1mV to 3.5mV (change by 2.5mV).

$$PSRR_Q = 20 \lg \left| \frac{250}{2.5} \right| = 40\text{dB}$$

◆ Delay time t_{pd} and Response time t_{response}

Both delay time and response time are used to characterize the time difference between primary side and secondary side;

The delay time is the time difference when the secondary output reaches 20% of the steady-state output value and the primary output reaches 20% of the steady-state current;

The response time is the time difference when the secondary output reaches 90% of the steady-state output value and the primary output reaches 90% of the steady-state current.

Rise Time t_r

The rising time is used to represent the time difference of the secondary side itself, that is, the time difference between the time when the output of the secondary side reaches 90% of the steady-state output value and 10% of the steady-state output value.

Power-On Time t_{po}

Power-On Time is defined as the time it takes for the output voltage to settle within $\pm 10\%$ of its steady-state value under an applied magnetic field, after the power supply has reached its minimum specified operating voltage.

High Accuracy Current Sensor with Pin-Selectable Gains and Adjustable Overcurrent Fault Detection

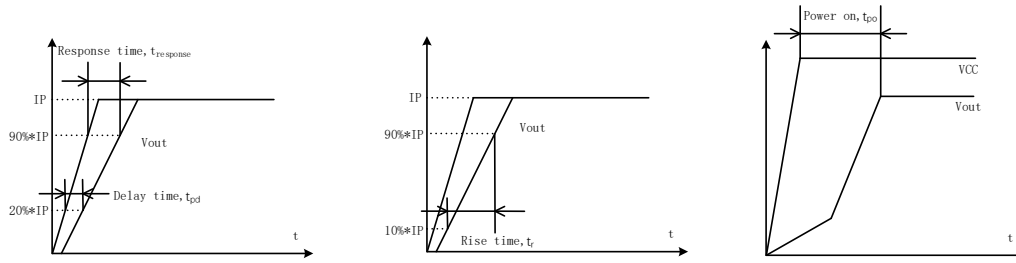

◆ Thermal resistance $R_{\theta JA}$

Based on a demo board, the thermal resistance is calculated by measuring the chip top temperature and power value. According to the thermal resistance, the junction temperature can be calculated as a reference. The actual surface temperature measurement value is shown in the relationship between the package temperature and the measured current.

$$T_J = T_A + (R_{\theta JA} * POWER) = T_A + (R_{\theta JA} * IP^2 * R_{PRIMARY});$$

Where T_J is junction temperature and T_A is ambient temperature.

◆ Reference application circuit diagram

When using SC82**FT**F5/B5/U5, VREF is the output mode.

1. Schematic diagram of connection between SC824/5 and overcurrent detection

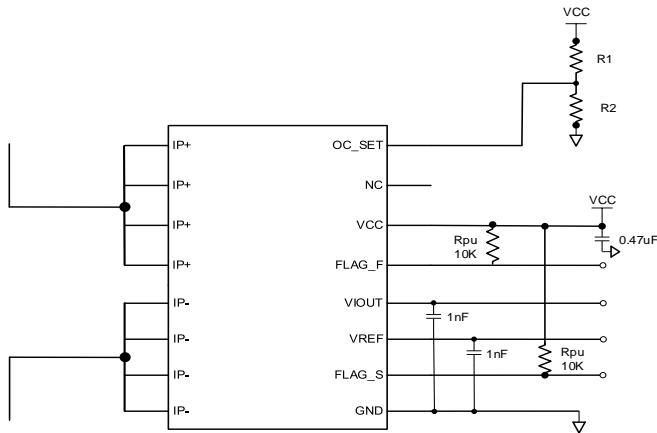

Note: If you do not need the overcurrent protection function, you can choose to use the OC_SET, FLAG_S, FLAG_F three-pin floating NC or connect to GND.

2. SC824C Gain Selection Application Diagram:

Note1: G0 and G1 are the gain setting bits, which support the user's external pull-up and pull-down configuration to achieve gain selection, please refer to < Gain selection application >

High Accuracy Current Sensor with Pin-Selectable Gains and Adjustable Overcurrent Fault Detection

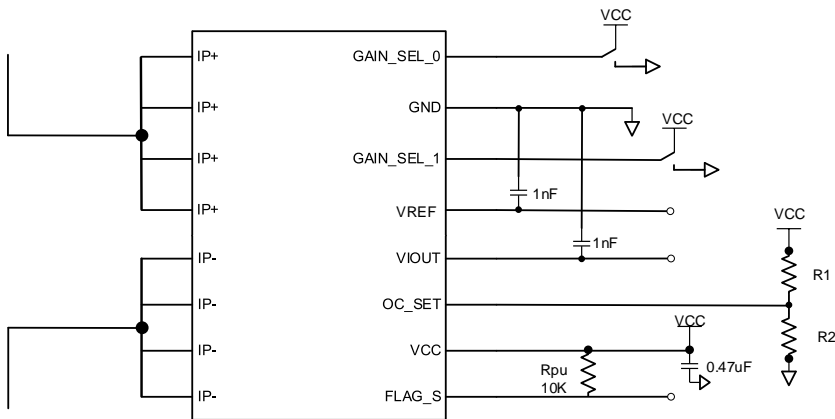

3. Schematic diagram of the differential application of VIOUT and VREF of SC824/5: $VIOUT = IP * Sensitivity * (5R/R)$ in the figure below.
 Note2: The SC824 provides a VREF reference output pin for back-end differential application circuitry.

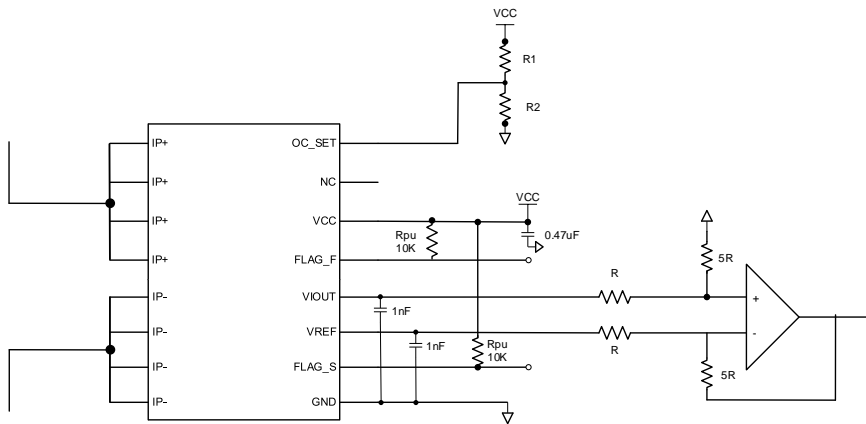

High Accuracy Current Sensor with Pin-Selectable Gains and Adjustable Overcurrent Fault Detection

PCB Demo Evaluation Board Layout

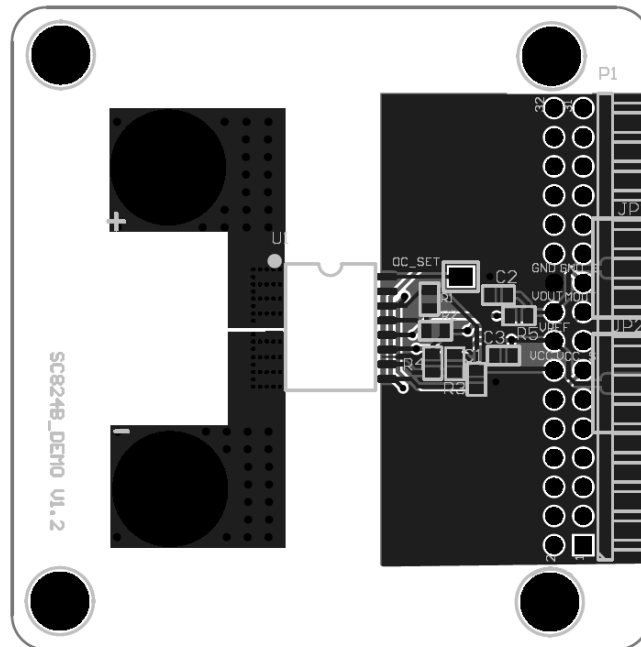

Mark Description

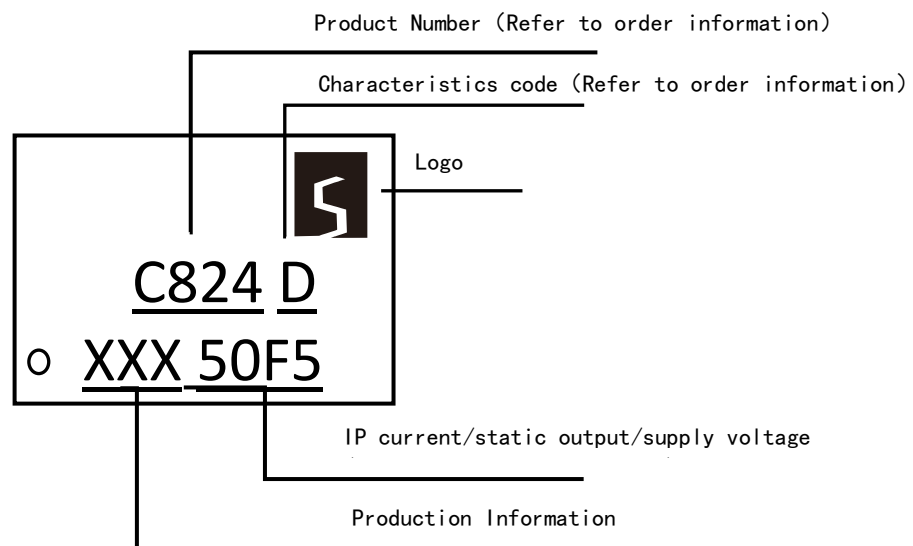

Note: X is non fixed character, defined by SENK SEMI naming rules

High Accuracy Current Sensor with Pin-Selectable Gains and Adjustable Overcurrent Fault Detection

Package Information

Note: all dimensions are in millimeters.

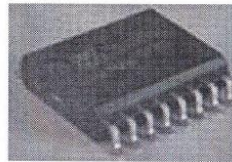
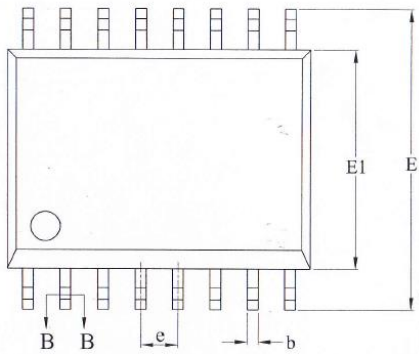
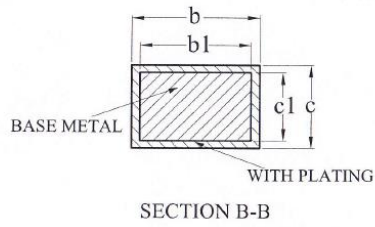
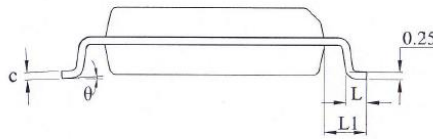
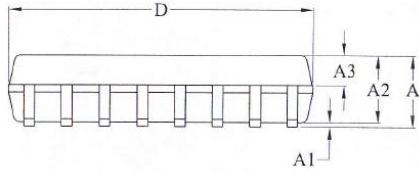

SYMBOL	MILLIMETER		
	MIN	NOM	MAX
A	—	—	2.65
A1	0.10	—	0.30
A2	2.25	2.30	2.35
A3	0.97	1.02	1.07
b	0.35	—	0.43
b1	0.34	0.37	0.40
c	0.25	—	0.29
c1	0.24	0.25	0.26
D	10.20	10.30	10.40
E	10.10	10.30	10.50
E1	7.40	7.50	7.60
e	1.27BSC		
L	0.55	—	0.85
L1	1.40REF		
θ	0	—	8°

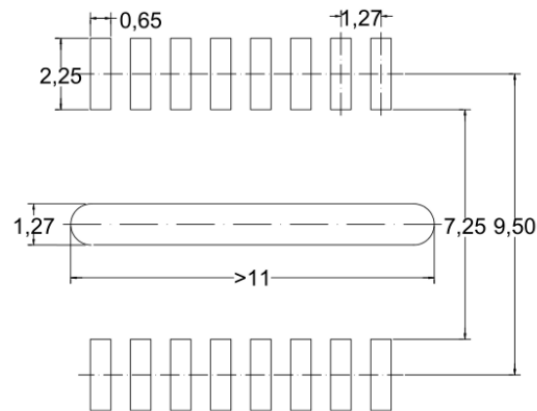

PCB Layout Reference View

High Accuracy Current Sensor with Pin-Selectable Gains and Adjustable Overcurrent Fault Detection

Packing information

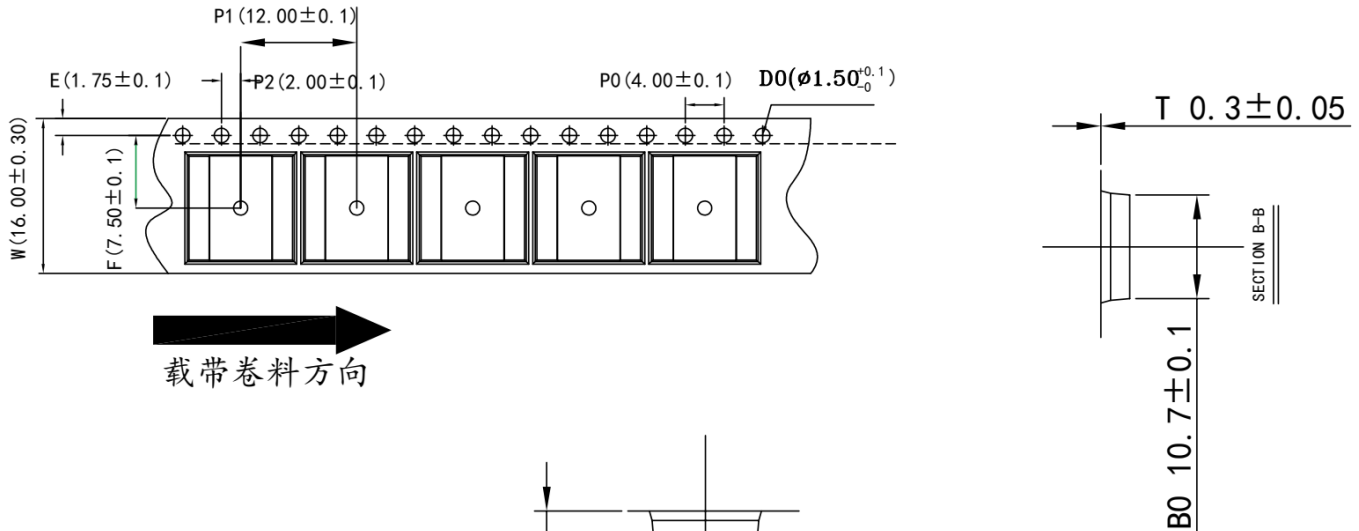

Notes:

1. 10 sprocket hole pitch cumulative tolerance $\pm 0.20\text{mm}$
(每10个链轮齿孔直径累计公差为 $\pm 0.2\text{MM}$)
2. Carrier camber not to exceed 1mm in 250mm.
(传送料带弯曲变形度每100MM不超过1MM)
3. A₀ and B₀ measured on a plane 0.3mm above the bottom of the pocket. (A₀与B₀在同一平面测量且距口袋底部0.3MM)
4. K₀ measured from a plane on the inside bottom of the pocket to the top surface of the carrier.
(K₀为口袋底部与材料表面的平面距离。)
5. All dimensions meet EIA-481-D requirements.
(所有尺寸符合EIA-481-D标准要求。)
6. Material: Black polystyrene
(材料:黑色聚苯乙烯。)
7. Thickness: $0.3 \pm 0.05 \text{ mm}$.
(厚度: 0.3 ± 0.05 毫米。)
8. Packing length per 22" reel : 200 Meters.
(每个22"卷轴包装长度为 200米。)
9. Component loader per 13" reel : pcs.
(每个13"卷轴可装个零件。前后各空 PCS)

注：未注明公差为 ± 0.1 ；
F值以B₀为中心；
P₂值以A₀为中心。

High Accuracy Current Sensor with Pin-Selectable Gains and Adjustable Overcurrent Fault Detection

Important Notice

SENK SEMI. CO., Ltd. Reserves the right to make, from time to time, such departures from the detail specifications as may be required to permit improvements in the performance, reliability, or manufacturability of its products. Before placing an order, the user is cautioned to verify that the information being relied upon is current.

SENK SEMI.'s products are not to be used in life support devices or systems, if a failure of an SENK SEMI. product can reasonably be expected to cause the failure of that life support device or system, or to affect the safety or effectiveness of that device or system.

The information included herein is believed to be accurate and reliable. However, SENK SEMI. CO., Ltd. assumes no responsibility for its use; nor for any infringement of patents or other rights of third parties which may result from its use.

For the latest version of this document, visit our website: www.senkomico.com

Revision History

Revision	Change	Page	Author	Date
1.0	Initial draft		Deng	2020.12.01
2.0	Adding safety certification; Adding SC825EFT series; Modifying FLAG_S Function. Modifying packing; Modifying PCB Layout Reference View; Add SC824EFT-30F5/SC825EFT-75F3/ SC824DFT-100F5/ SC824DFT-40F5/SC824DFT-80F5/ SC824DFT-10F5/ SC824DFT-30U5/ SC824DFT-25F5/ SC825BFT-105F3/		ZJF	2023.06.09
3.0	SC825DFT-65F3/ SC825DFT-25F3/ SC825DFT-10F3/ SC825CGT-30F3& SC825DFT-20F3& SC825CGT-40F3& SC825CGT-65F3& SC824DFT-75F5; Add SC825DGT-30F3&SC825DFT-50F3& SC825CGT-65U3 model and add performance parameter table; Added the performance parameter table of the SC824DFT-75F5; Add SC825CGT-65U3&SC825DFT-65U3 models, and add SC825 models with performance parameter table and pin definition silk screen. Add SC825DFT-80F3&SC825DFT-100F3; Add SC825DFT performance parameter table; Add SC824CGT-50F5 model and performance parameter table; Add SC824DFT-25U5&SC825AFT-79F3; Added the SC824CGT-75F5 model and performance parameter table;		MWJ	2024.01.31