

Automotive Qualified, 240kHz Bandwidth, Programmable Linear Hall Effect Sensor IC

Description

SL6240 series is a programmable linear hall sensor IC featuring the high bandwidth and high precision. After programmed, it is sensitive to the flux density applied orthogonally to the IC surface. The SL6240 provides an output signal proportional to the applied magnetic flux density and is designed for current measurement. The programmable feature can configure the sensitivity, quiescent (zero field) output voltage, reference voltage and temperature compensation coefficient through programming with the Vout pin on power-on condition. The configure parameters are programmed into the non-volatile memory so as to ensure the IC's stability in worse electrical and magnet environment.

The SL6240 can be easily used in combination with a ring shaped soft ferromagnetic core. The hall IC is placed in a small air gap and the current conductor is passed through the inner part of the magnetic ring. The ring concentrates and amplifies the magnetic flux on the SL6240, which generates an analog output voltage proportional to the current flowing in the conductor after custom programming.

SENK SEMI. is a global IC supplier focusing on programmable sensor condition ASIC.

Features

- Automotive qualified , AEC-Q100
- Single power supply from 3.3V or 5.0V
- Fantastic Wide dynamic sensitivity range from 2 to 20 mV/G
- Fixed output voltage 2.5V
- Factory-programmed segmented temperature compensation and delivers a solution with
 - ◇ $\pm 1.5\%$ sensitivity error and $\pm 5\text{mV}$ Offset error over $25^{\circ}\text{C}\sim 125^{\circ}\text{C}$
- Differential Vref Output mode: $V_{\text{out}} - V_{\text{ref}}$
 - ◇ The quiescent error of $V_{\text{out}} - V_{\text{ref}}$ can be adjusted to be $< \pm 3\text{mV}$ @ Room temperature.
- High drive capacity
- Non-Ratio metric output mode
- Faster Response time $< 2\mu\text{s}$
- High operating bandwidth: up to 240kHz
- Wide ambient temperature range: $-40^{\circ}\text{C}\sim 125^{\circ}\text{C}$
- Independent intellectual Property Rights

Package View

Top view

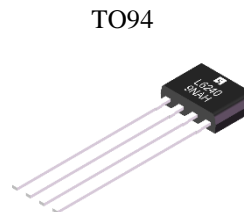

Typical Application

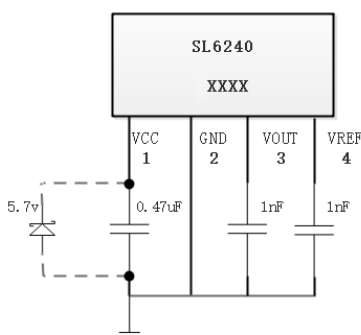

Order information

Part Number	Characteristics code	Qualified level	Temp Range	Packing	Default sensitivity (mV/G)	sensitivity range (mV/G)
SL6240-A1FB	A	1 (Aec-Q100 Grade 1)	F(-40~125°C)	B(1k/Bag)	2.8	2 ~3.6
					5	3.6 ~6.5
					9	6.5 ~ 11.5
					16	11.5 ~ 20
SL6240-C1FB	C	1 (Aec-Q100 Grade 1)	F(-40~125°C)	B(1k/Bag)	2.8	2 ~3.6
					5	3.6 ~6.5
					9	6.5 ~ 11.5
					16	11.5 ~ 20

Note1: The default 5.0V and 3.3V single supply and fixed output voltage is 2.5V and 1.65V. If there are other output requirements, please contact FAE for confirmation

Note 2: Allows 4 levels of sensitivity to be set via the calibration tool.

Pin Configuration (Top view)

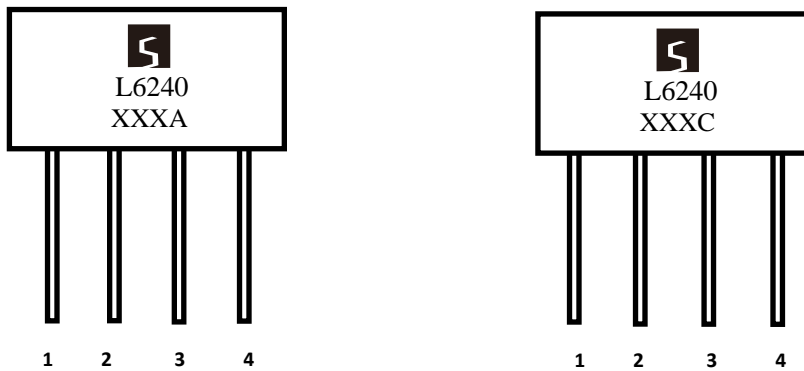

6240A Pin Name	6240C Pin Name	Pin Name	Description
1	1	VCC	Device power supply terminal
2	4	GND	Signal Ground terminal
3	2	VOUT	Analog output signal, also should be used to programming digital I/O
4	\	VREF	Reference terminal, support differential output mode
\	3	NC	There is no electrical connection to the chip and it is suspended by default

Functional Block Diagram

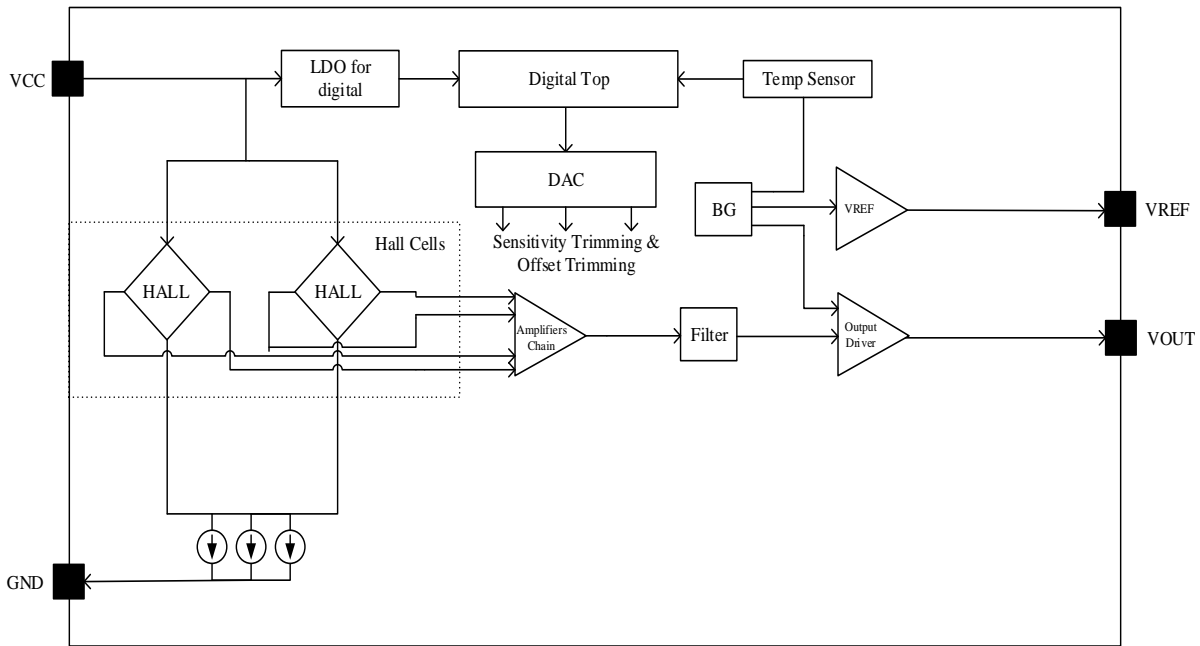

Absolute Maximum Ratings

Absolute maximum ratings are limiting values to be applied individually, and beyond which the serviceability of the circuit may be impaired. Functional operability is not necessarily implied. Exposure to absolute maximum rating conditions for an extended period of time may affect device reliability.

Symbol	Parameter	Notes	Rating	Unit
V _{CC}	Supply voltage		6.0	V
V _{RCC}	Reverse Supply Voltage		-0.1	V
V _{OUT}	Output voltage		6	V
V _{ROUT}	Reverse Output Voltage		-0.1	V
V _{REF}	Output voltage		6	V
V _{RREF}	Reverse Output Voltage		-0.1	V
T _A	Nominal Operating Ambient Temperature	Range G	-40~150	°C
		Range F	-40~125	
T _{J(max)}	Maximum Junction Temperature		165	°C
T _{STG}	Storage Temperature		-65~165	°C
I _{REF Source Current}	Vref Current Sour	Vref shorted to GND.	15	mA
I _{REF Sink Current}	Vref Current Sink	Vref shorted to VCC	15	mA
I _{OUT(Source)}	Output Current Source	Shorted Output-to-Ground Current	30	mA
I _{OUT(Sink)}	Output Current Sink	Shorted Output-to-VCC Current	30	mA
ESD	HBM mode		8	KV

External Capacitor

Device	Test Condition	Min.	Typ.	Max.	Units
C _{Bypass}	Power filter capacitor, connected between VCC / GND	0.1	0.47		uF
C _{Load}	V _{OUT} filter capacitor, connected between VOUT / GND		1		nF
C _{VREF}	V _{REF} filter capacitor, connected between VREF / GND		1		nF

Common Operating Characteristics

Note: Over full range of T_A= -40°C ~ 125°C, C_{Bypass}=0.47uF, C_{Load}=1nF, C_{VREF}=1nF, V_{CC}=5V, unless otherwise specified.

Parameter	Symbol	Test Condition	Min.	Typ.	Max.	Units
Supply Voltage	V _{CC}	5V nominal supply voltage variant	4.5	5.0	5.5	V
		3.3V nominal supply voltage variant	3.0	3.3	3.6	
Supply Current	I _{CC}	5V nominal supply voltage variant		21		mA
		3.3V nominal supply voltage variant		15		
Quiescent Output Voltage	V _{OUT} and V _{REF}	5V nominal supply voltage		2.5		V
		3.3V nominal supply voltage		1.65		V
Output Load Resistance	R _L	VOUT to Gnd	2			kΩ
Vref Load Resistance	R _L	VREF to Gnd	2			kΩ
Nonlinearity	E _{LIN}	Measured using full-scale and half-scale IP			1	%
Response Time	t _{response}			2		μS
Rise time	t _r			2.2		μS
Response delay time	t _{pd}	IP= Full scale		1.15		μS
Power-On Time	t _{PO}	Output reaches steady state level		150		μS
Frequency Bandwidth	F	Small signal -3 dB C _L =1nF		240		kHz
V _{OUT} linear rail to rail output range	V _{rail-rail}	R _L =2kΩ	10		90	% VCC

User Programming-related Parameter Table

Note: $C_{\text{Bypass}}=0.47\mu\text{f}$, $C_{\text{Load}}=1\text{nF}$, $C_{\text{VREF}}=1\text{nF}$, $V_{\text{CC}}=5\text{V}$, unless otherwise specified.

Parameter	Symbol	Test Condition	Min.	Typ.	Max.	Units
Quiescent Voltage Output (V_{OUT})						
Quiescent Voltage Output Programming Range	V _{OUT(Q)}	T _A = 25°C	-400		400	mV
Quiescent Voltage Output Programming Bits ^[1]	Q _{VO}			9		bit
Average Quiescent Voltage Output Programming Step Size	Step _{V_{OUT}(Q)}	V _{out_offset} , T _A = 25°C		1.5		mV
Sensitivity (Sens)						
Coarse sensitivity programming bit ^[2]	Sens_Coarse		-	2	-	bit
Middle Sensitivity Programming Bits ^[3]	Sens_Middle		-	3	-	bit
Fine Sensitivity Programming Bits ^[4]	Sens_Fine		-	9	-	bit
Sensitivity Programming Range ^[5]	Sens_PR	T _A = 25°C	2	-	3.6	mV/G
			3.6	-	6.5	mV/G
			6.5	-	11.5	mV/G
			11.5		20	mV/G
Average Fine Sensitivity Programming Step Size	Step _{SENS_Fine}	T _A = 25°C	-	5.6	-	μV/G
			-	10	-	μV/G
			-	18	-	μV/G
			-	32	-	μV/G
Others						
Magnetic reversa		Reverse induction 1b0: default 1b1: opposite polarity		1		Bit
EEPROM LOCK		EEPROM LOCK		1		Bit

[1] **V_{OUT} OFFSET** : Quiescent voltage output(no significant magnetic field: B=0G), the output V_{OUT} and the adjusted offset voltage difference value. Register Reg0x1a[6] is used for offset, step tuning range selection. See User Programming Manual.

[2] **Sens Coarse**: Coarse adjustment sensitivity register, output voltage increases with the magnitude of the applied magnetic field.This register is controlled by Reg0x0f [3:2] and has 4 adjustable gain values. See User Programming Manual.

[3] **Sens Middle**: Middle sensitivity register, output voltage increases with the magnitude of the applied magnetic field.This register is controlled by Reg0x0f [6:4] and has 8 adjustable gain values. See User Programming Manual.

[4] **Sens Fine** : Fine sensitivity register, the output vltage increases with the magnitude of the applied magnetic field.This register is controlled by Reg0x03[7] and Reg0x04 [7:0] and has 512 gain values adjustable. See User Programming Manual.

[5] Device performance is guaranteed within these ranges.

Temperature Coefficient

Note: $C_{\text{Bypass}}=0.47\mu\text{f}$, $C_{\text{Load}}=1\text{nF}$, $V_{\text{CC}}=5\text{V}$, $C_{\text{VREF}}=1\text{nF}$, unless otherwise specified.

Parameter	Symbol	Test Condition	Min.	Typ.	Max.	Units
Quiescent Voltage Output (VOUT)						
Quiescent Voltage Output Drift Through Temperature Range	$V_{\text{OUT TC}}$	$T_{\text{A}} = 25^{\circ}\text{C}$	-5		5	mV
		$T_{\text{A}} = 25^{\circ}\text{C}$ to 125°C	-10		10	mV
		$T_{\text{A}} = -40^{\circ}\text{C}$ to 25°C	-10		10	mV
Reference Voltage Output (VREF)						
Reference voltage output Drift Through Temperature Range	$V_{\text{REF TC}}$	$T_{\text{A}} = 25^{\circ}\text{C}$	-5		5	mV
		$T_{\text{A}} = 25^{\circ}\text{C}$ to 125°C	-10		10	mV
		$T_{\text{A}} = -40^{\circ}\text{C}$ to 25°C	-10		10	mV
Differential Voltage Error ($V_{\text{REF}} - V_{\text{OUT}}$)						
Differential voltage output Drift Through Temperature Range	$E_{\text{VOE TC}}$	$T_{\text{A}} = 25^{\circ}\text{C}$	-5		5	mV
		$T_{\text{A}} = 25^{\circ}\text{C}$ to 125°C	-8		8	mV
		$T_{\text{A}} = -40^{\circ}\text{C}$ to 25°C	-8		8	mV
Sensitivity Temperature Coefficient						
Sensitivity Drift Through Temperature Range	$E_{\text{SENS TC}}$	$T_{\text{A}} = 25^{\circ}\text{C}$ to 125°C	-2		2	%
		$T_{\text{A}} = -40^{\circ}\text{C}$ to 25°C	-1.5		1.5	%

Accuracy Characteristic Curve

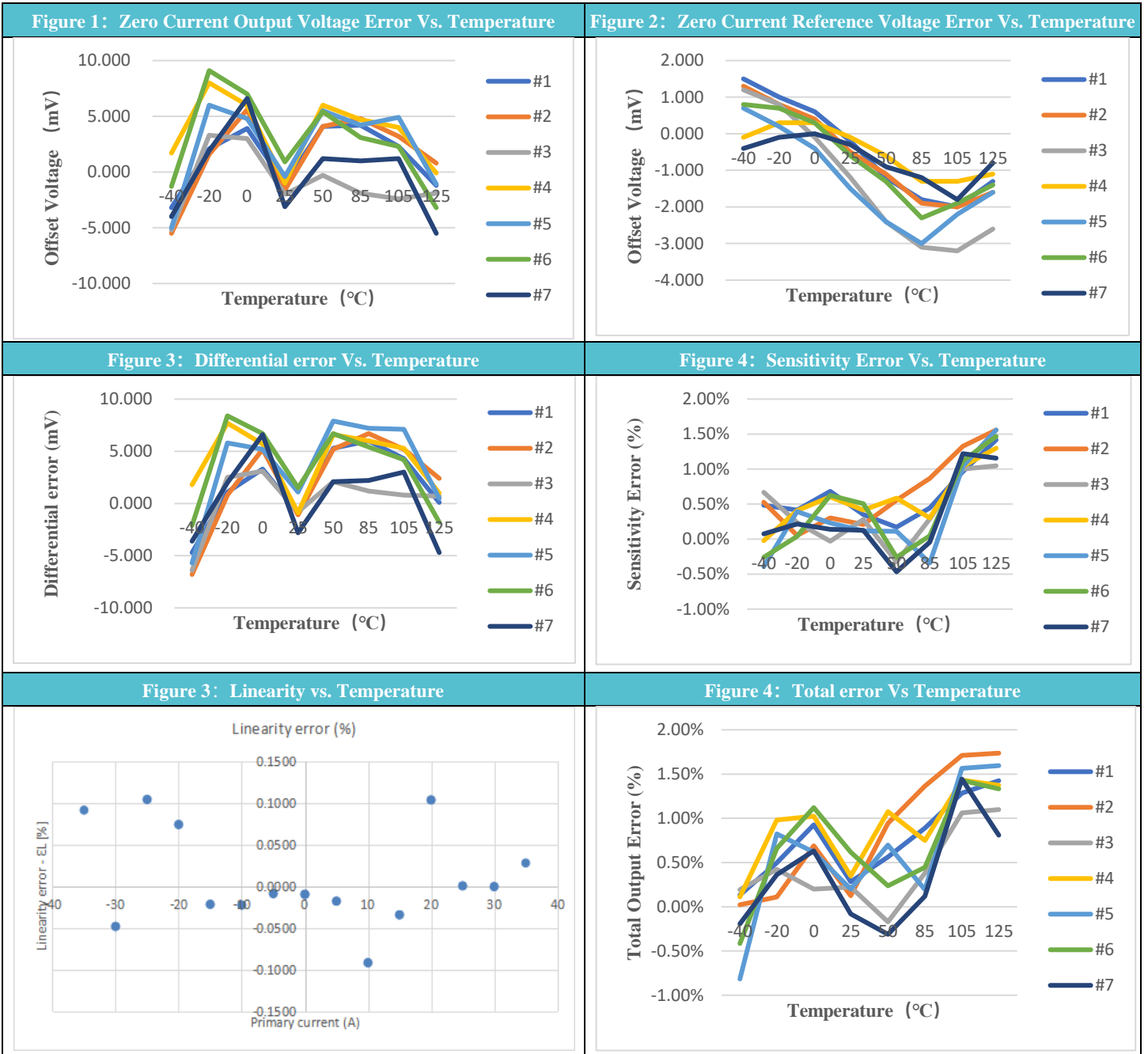

AC characteristic diagram

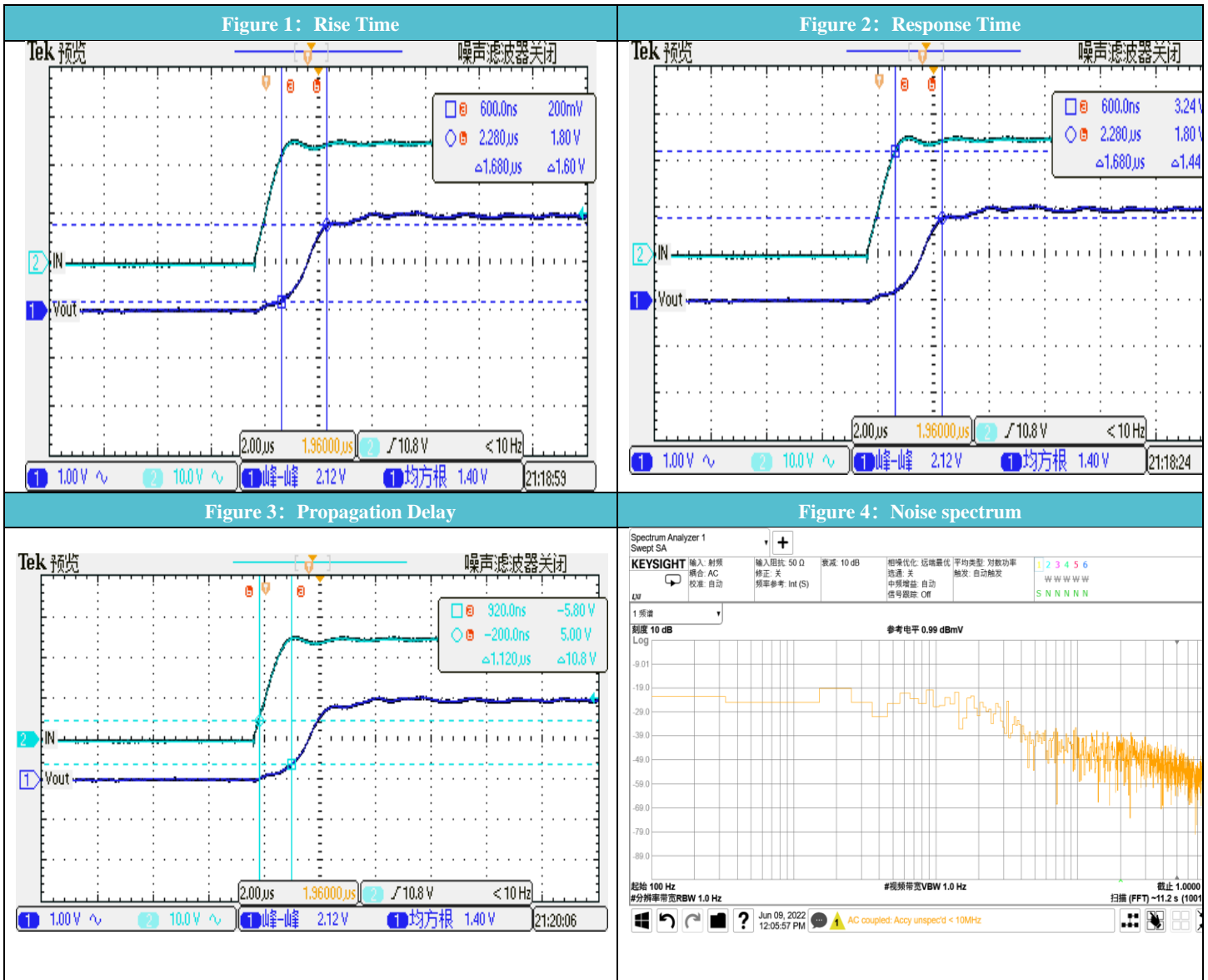

Dynamic characteristic curve

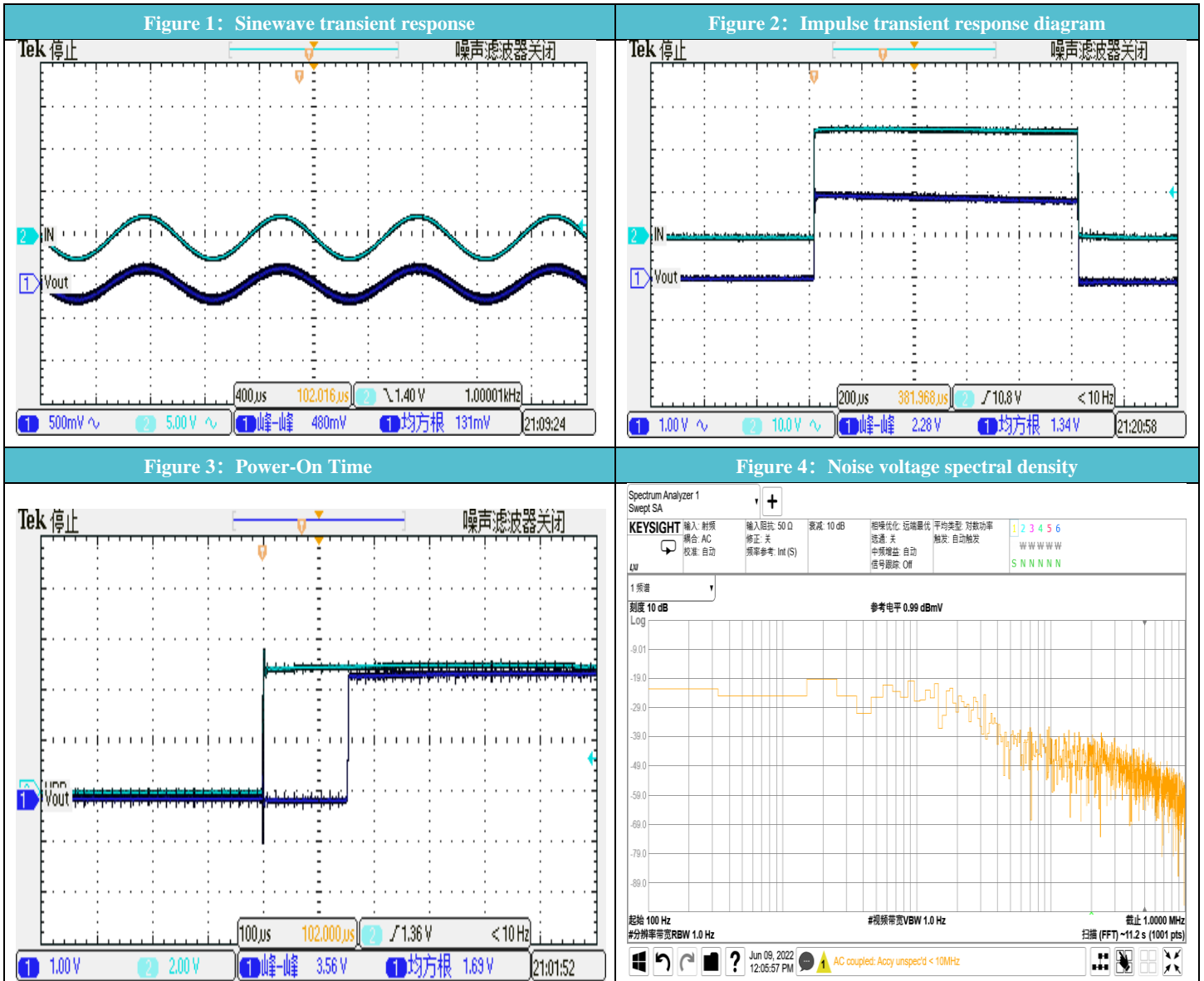

Feature reference application

◆ SL6240 Application of VREF

VREF is equal to static output value (without external magnetic)

The relationship between VOUT and VREF: $VOUT = B * SENS + VREF$ (B: flux magnetic)

◆ Delay time tPD and response time tresponse

Propagation Delay (tpd)

The time interval between a) when the applied magnetic field reaches 20% of its final value, and b) when the output reaches 20% of its final value

Response Time (tRESPONSE)

The time interval between a) when the applied magnetic field reaches 90% of its final value, and b) when the sensor reaches 90% of its output corresponding to the applied magnetic field. The parameter is also shown in the Electrical Characteristics table and in the performance data table.

Rise Time (tr)

The time interval between a) when the sensor IC reaches 10% of its final value, and b) when it reaches 90% of its final value Power-On Time (tPO)

Power on time is used to describe the time difference between the secondary side and the power supply VCC, that is, the time difference between the secondary side output and the VCC when it reaches the steady-state output value.

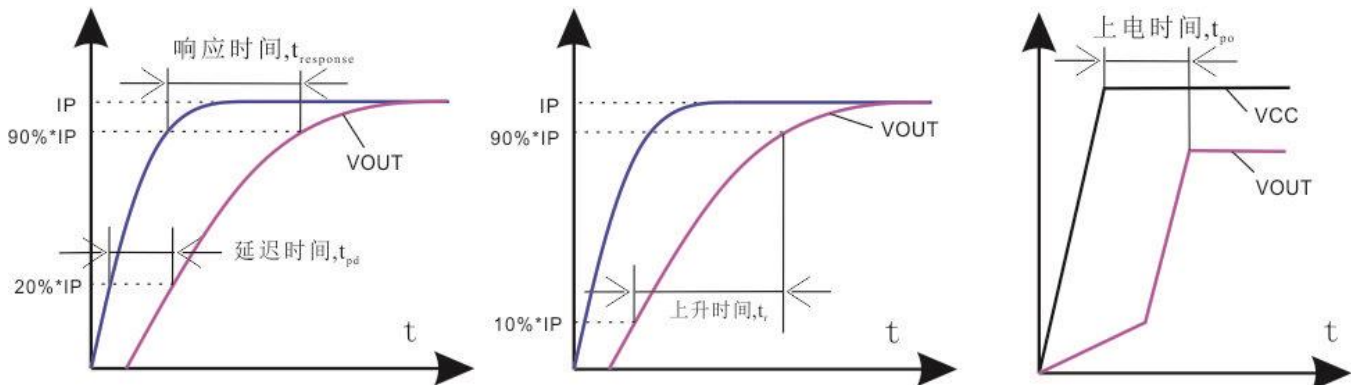

Application circuit diagram

1) SL6240 and ADC connection diagram

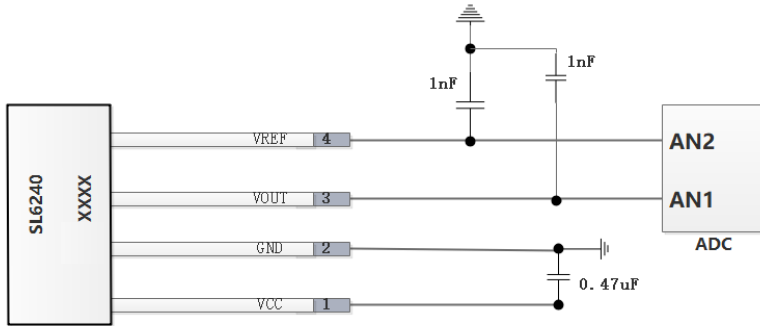

VREF is the output terminal when selecting 2.5V function.

2) Schematic diagram of differential mode between VOUT and VREF of SL6240 :

Pictured : $V_{OUT} = I_P * Sensitivity * (5R / R)$

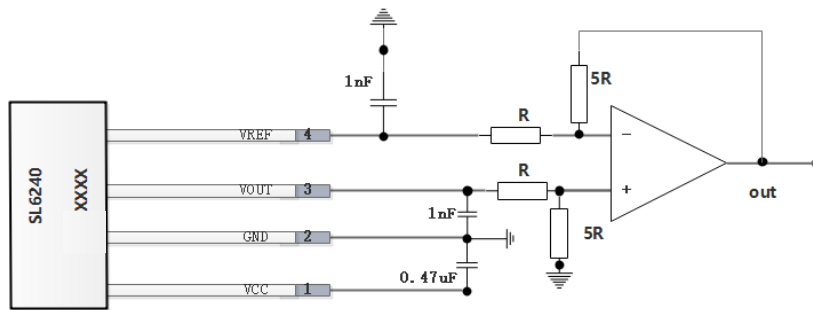

3) When VREF is selected as the input terminal, VREF voltage can be modified to 0.5 ~ 2.6V, and VOUT static voltage is equal to VREF voltage

(Not open, please contact FAE)

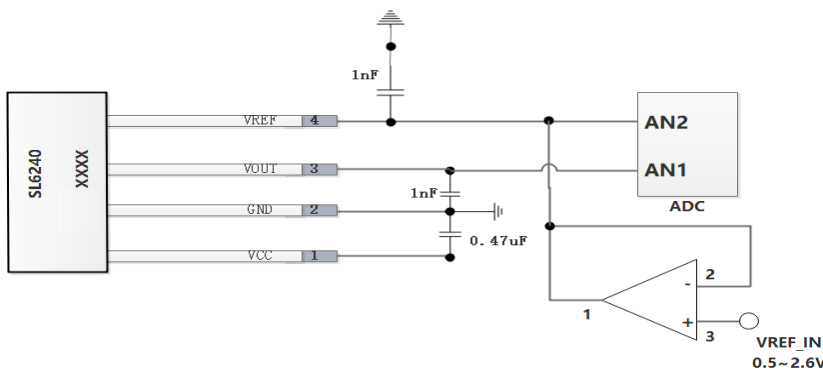

4) Magnetic induction direction selection

Characteristic	Symbol	Test Condition	Min	Typ	Max	Units
Magnetic reversal	-			1		Bit
		Reverse induction 1b0: default 1b1: opposite polarity	-	-	-	-

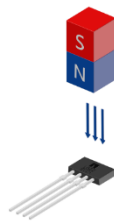

Note:

- By default, when the N-pole magnetic field is close to the identification surface of SL6240, the voltage output will rise accordingly.
- When {opposite polarity} is selected, when the magnetic field is S-pole close to the SL6240 identification surface, the voltage output will rise accordingly.

Programming System

The SL6240 incorporates a serial interface that allows an external controller called SP102 to automatically calibrate in the MTPROM. Please contact with FAE of SENK SEMI.

Email: fae@senkomicom.com

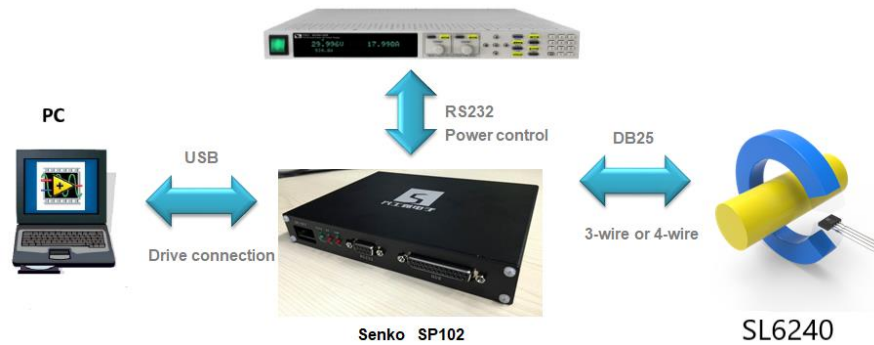

calibration system

- The programming hardware takes SP102 as the core, the USB serial port installation driver realizes the PC connection, and the RS232 serial port transmission command realizes the control current source; the DB25 serial port provides high-precision 5V power supply for the IC, and the VOUT as the programming pin realizes the communication transmission. The following figure is a description of the transformation process.

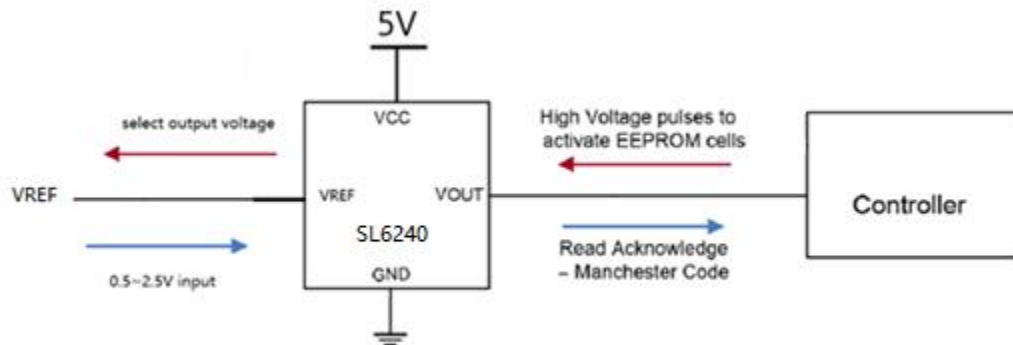

◆ Mark Description

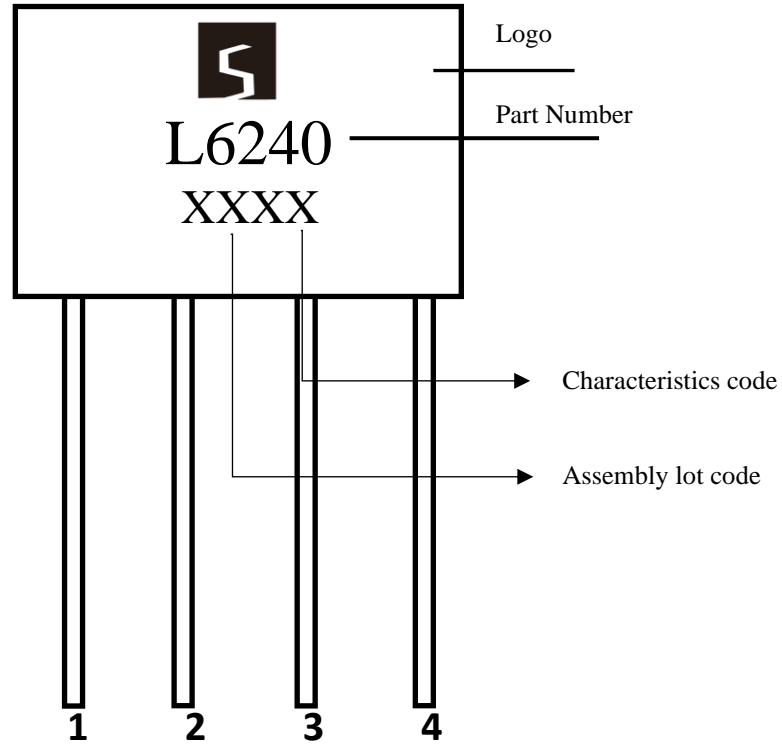

SL6240

High Precision, Programmable Linear Hall Effect Sensor

Package Information

Note: all dimensions are in millimeters.

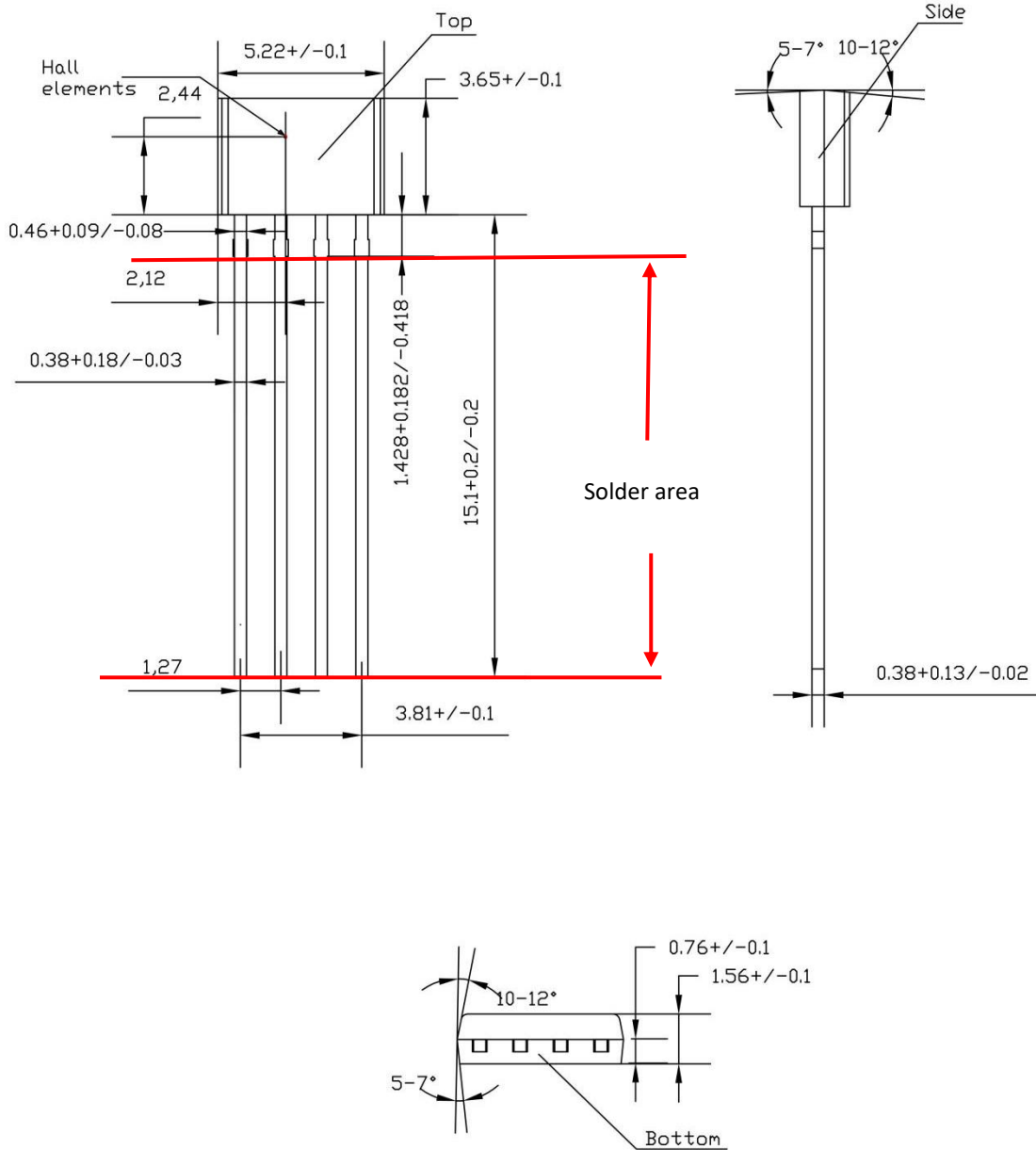

Important Notice

SENK SEMI. co., Ltd. Reserves the right to make, from time to time, such departures from the detail specifications as may be required to permit improvements in the performance, reliability, or manufacturability of its products. Before placing an order, the user is cautioned to verify that the information being relied upon is current.

SENK SEMI.'s products are not to be used in life support devices or systems, if a failure of a SENK product can reasonably be expected to cause the failure of that life support device or system, or to affect the safety or effectiveness of that device or system.

The information included herein is believed to be accurate and reliable. However, SENK SEMI. co., Ltd. Assumes no responsibility for its use; nor for any infringement of patents or other rights of third parties which may result from its use.

Revision Table

Revision	Change	Page	Author	Date
1.0	Define for current sensing		Jon	2021.12.01
2.0	Confirm order info.; Modify User Programming-related parameter table; Add solder area; Product model Compatible with 3.3V or 5V; Product model name and screen printing changed; Add SL6240C1FB; Update HBM parameters; Update the encapsulated POD information;		MWJ	2024/8/26