

Automotive-Grade , Up to150A, High Accuracy Current Sensor with Adjustable Over Current Fault Detection

Description

The SC8450 series is a new member of SENK SEMI.'s fully integrated current sensor product line, With the industry's first packaging technology, current wire impedance as low as 0.24mΩ is achieved on a wide-body SOP-16 package of 10mm*11mm*2.3mm, It can be used in power systems requiring measurements up to 150A. Suitable for customers for batch automatic patch production, it is the best solution for small volume, high current applications.

The SC8450 series is an isolated current detection chip that operates on the open-loop Hall sensor detection principle. By introducing the current conductor on the high voltage side into the package, based on the magnetic effect of the current, the equal-proportional magnetic field generated around the measured conductor is induced by the magnetic sensor of the built-in chip and converted into the equal-proportional voltage signal that can be processed, The voltage signal is read and amplified by the built-in high-precision ADC, and with digital calibration technology, environmental variables such as temperature, noise, hysteresis, nonlinearity and so on are removed, and the final output voltage value is nearly ideal ratio with the measured current value, so as to achieve isolated current measurement.

The SC8450 series adds built-in and adjustable fault monitoring with an open drain output, and its built-in FLAG_F uses a built-in fixed fault threshold without requiring any additional components, Built-in protection response of less than 2uS can be achieved, Very suitable for severe short-circuit fault detection. FLAG_S supports users to set their own fault thresholds using peripheral divider resistors, And the current pulse shielding setting can ignore the interference in the application to prevent false alarms, very suitable for mild overcurrent detection and feedback peak setting. This function is flexible in fault detection and greatly simplifies the circuit board application layout.

Features

- AEC-Q100 automotive qualified
- Isolated measurement, isolated voltage up to 4.8kv @50HZ,1min
- Can measure DC, AC current
- Signal detection bandwidth up to 240khz
- Lowest current wire impedance:0.24mΩ
- Differential sensing technology has high anti-interference ability to the external environment
- User configurable fault detection function
FLAG_F: Built-in protection, suitable for severe short circuit detection
FLAG_S: Adjustable protection for overload detection and user configuration
- Static voltage output support: 0.1VCC/0.5VCC
- Response time as low as 2uS
- Wide range of measured current: 0A~150A
- High accuracy: Accuracy error < 1% at 25°C
Operating temperature: Accuracy error<3%
- Strong driving capability, supporting output ports with loads as low as 2kΩ
- Independent intellectual property rights, no technology dependence
- Isolation safety certification:



Package

◆ Top View:
(mark information is not subject to this rule)

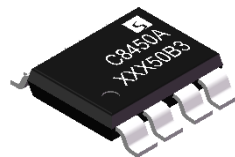

Current Path view:

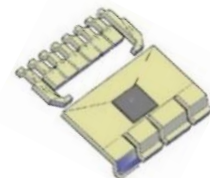

Typical Application

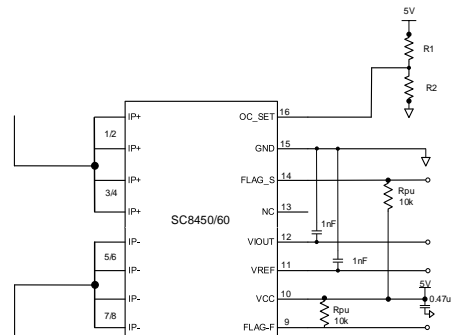

SC8450/SC8460 series

Up to 150A, High Accuracy Current Sensor with Adjustable Over Current Fault Detection Current Sensor IC

Order information

Part Number	Characteristics code	Qualified level	Temp Range	Packing	Current IP Range (A)	0A Output* ¹ (V)	Sensitivity* ² (mV/A)	Supply voltage (V)
SC8450A1FT-100B3	A	Grade 1 (Aec-Q100)	F(-40~125°C)	T (Reel, 1000 pieces/reel)	± 100	0.5V _{cc}	13.2	3.3
SC8450A1FT-150B3					± 150	0.5V _{cc}	8.8	
SC8450A1FT-50F3					± 50	1.65	26.4	
SC8450A1FB-150F3					± 150	1.65	8.8	
SC8460A1FT-100B5					± 100	0.5V _{cc}	20	5.0
SC8460A1FT-150B5					± 150	0.5V _{cc}	13.33	
SC8460A1FT-50F5					± 50	2.5	40	
SC8460A1FT-150F5					± 150	2.5	13.33	

Note1: Type B and F Reference output types when IP=0A

B	When IP has no current, VIOUT@0A=VREF=0.5V _{CC} , suitable for bidirectional current detection, zero point and sensitivity change with VCC ratio
F	When there is no current in the IP, VIOUT@0A=VREF=2.5V/1.65V, which is suitable for bidirectional current sensing, and the zero point and sensitivity vary with VCC ratio

Note2: Factory shipment default Mask=0uS, this function is turned off, if the customer needs to turn on the function, you can ask our FAE/ agent

Pin Configuration(Top view)

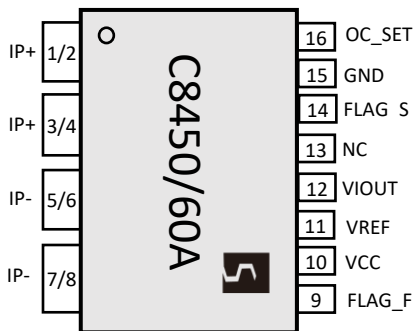

Pin number	Pin Name	Description
1/2/3/4	IP+	Terminals for current being sampled; fused internally, support connect to 1/2/3/4
5/6/7/8	IP-	Terminals for current being sampled; fused internally, support connect to 5/6/7/8
9	FLAG_F	Built-in fault output, built-in overcurrent threshold multiple
10	VCC	Device power supply terminal
11	VREF	Reference terminal, supporting input and output. Specifically define Note 1 of the above ordering information VIOUT= Vref (IP=0A)
12	VIOUT	Analog output signal, VIOUT=IP*Sens+Vref
13	NC	No connection
14	FLAG_S	Adjustable fault output
15	GND	Signal Ground terminal
16	OC_SET	External fault threshold voltage (support NC)

Up to 150A, High Accuracy Current Sensor with Adjustable
Over Current Fault Detection Current Sensor IC

Thermal Rise vs. Primary Current

Typical Plastic package temperature[°C] of SC8450/60 vs Primary current [A] based on Demo Board.

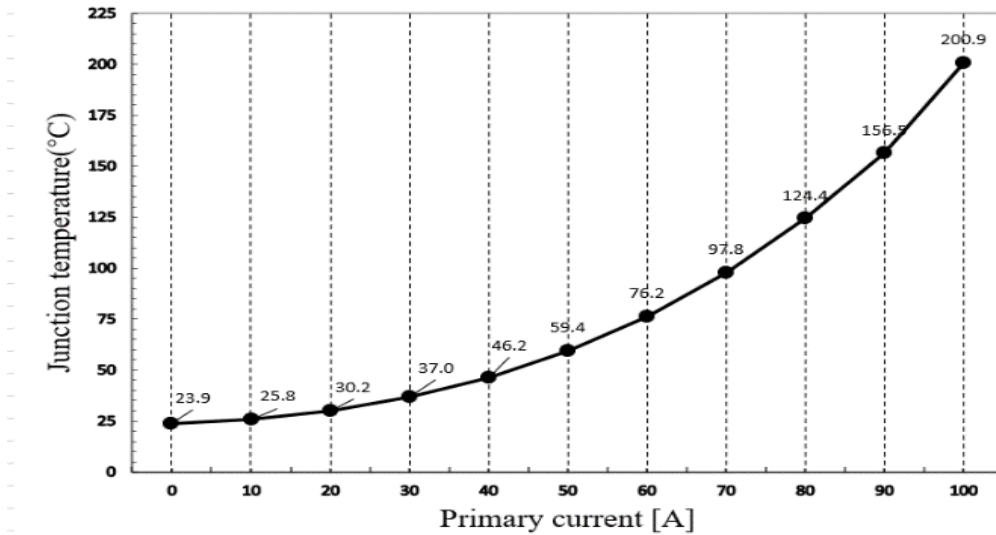

Demo Board information

	DEMO	Units
PCB Layer Number	2	
PCB Copper layer thickness	2	Oz
Total Copper size connected to Primary pins(including all layers)	350	mm ²
PCB Board Thickness	1.6	mm

Functional Block Diagram

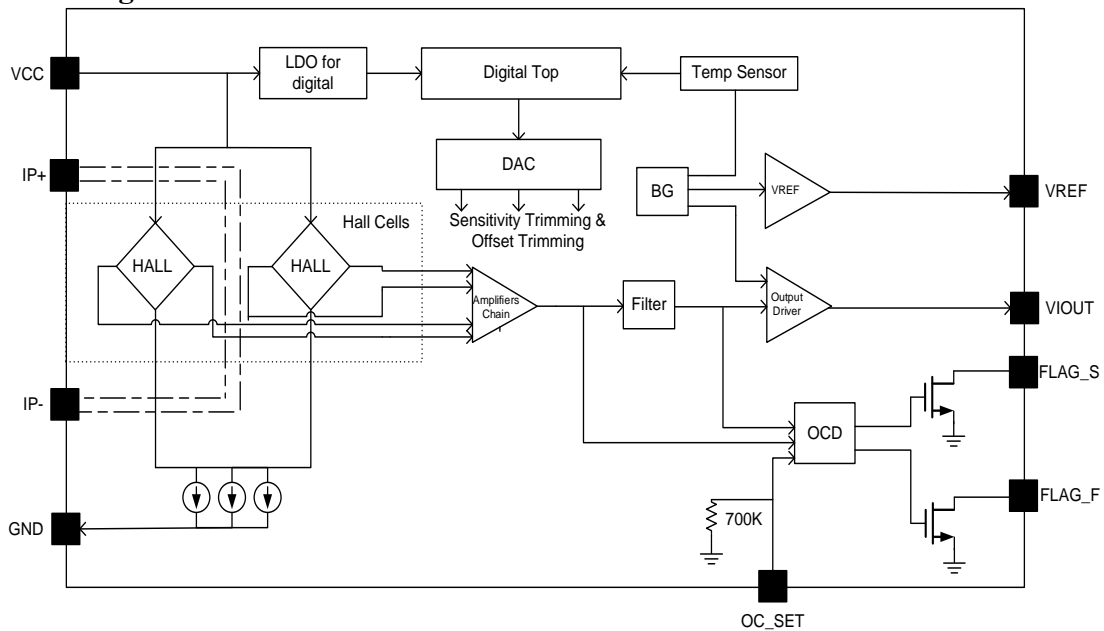

Up to 150A, High Accuracy Current Sensor with Adjustable Over Current Fault Detection Current Sensor IC

Absolute Maximum Ratings

Absolute maximum rating is the operating limit of a device, exceeding which may cause device damage. Frequent operation outside this value range may affect device reliability.

Symbol	Characteristic	Notes	Ratings	Units
V _{CC}	Supply voltage		6	V
V _{RCC}	Reverse Supply Voltage		-0.1	V
V _{IOUT}	Output Voltage		6	V
V _{RIOUT}	Reverse Output Voltage	V _{IOUT} , V _{REF}	-0.1	V
V _{FLAG}	Forward Output Voltage	applicable to the FLAG overflow function	6	V
V _{RFLAG}	Reverse Output Voltage		-0.1	V
V _{OC_SET}	Forward Output Voltage	applicable to the OC_SET function	6	V
V _{ROC_SET}	Reverse Output Voltage		-0.1	V
T _A	Operating Temperature	Range G	-40~150	°C
		Range F	-40~125	
		Range E	-40~85	
T _{J(max)}	Maximum Junction Temperature		165	°C
T _{stg}	Storage Temperature		-65~170	°C
I _{OUT(Source)}	Output Current Source	Shorted Output-to-Ground Current	30	mA
I _{OUT(Sink)}	Output Current Sink	Shorted Output-to-VCC Current	30	mA
I _{REF(Source)}	V _{ref} Current Source	Shorted V _{ref} -to-Ground Current	15	mA
I _{REF(Sink)}	V _{ref} Current Sink	Shorted V _{ref} -to-VCC Current	15	mA
I _{Pmax}	Maximum Continuing IP Current	Based on SENK's Demo Test Board	100	A
I _{POver}	Transient Over Current at Ambient Temperature	Based on SENK's Demo Test Board , 1pulse , 100ms , 1% Duty Cycle	400	A
ESD	HBM mode		4	kV

Isolation Characteristics

Symbol	Characteristic	Notes	Ratings	Units
V _{ISO}	RMS voltage for AC insulation test,50Hz,1min	Agency type-tested for 60 seconds per UL60950-1	4800	V _{rms}
V _{WVRI}	Working Voltage for Basic Isolation	Maximum working voltage according to UL60950-1	1500	V _{Peak}
D _{cl}	Clearance	Minimum distance through air from IP leads to signal leads	8	mm
D _{cr}	Creepage distance	Minimum distance along package body from IP leads to signal leads	8	mm
CTI	Comparative tracking index	the electrical breakdown (tracking) properties of an insulating material	600	V
V _{IOSM}	Maximum surge isolation voltage	Tested ±5 pulses at 2/minute in compliance to IEC 61000-4-5 1.2 μs (rise) / 50 μs (width).	10	kV
I _{IOSM}	Maximum Transient impulse current	Tested ±5 pulses at 3/minute with 8 μs (rise) / 20 μs (width)	20	kA

Note 1: Meet the safety certification of UL60950-1 and CB62368-1

Reference application Specification

Symbol	Description	Min	Typ	Max	Unit
C _{VCC}	The filter capacitor of power supply is connected between VCC and GND	0.1	0.47		μF
C _{V_{IOUT}}	The filter capacitor of Output is connected between Vout and GND		1		nF
C _{V_{REF}}	The filter capacitor of Output is connected between Vref and GND		1		nF
R _{FLAG_F}	The pull-up resistance is connected between FLAG_F and VCC		10		kΩ
R _{FLAG_S}	The pull-up resistance is connected between FLAG_S and VCC		10		kΩ

Up to 150A, High Accuracy Current Sensor with Adjustable Over Current Fault Detection Current Sensor IC

Common Electrical Characteristics

Note: Over full range of $T_A=25^{\circ}\text{C}$, $C_{\text{Bypass}}=0.47\mu\text{F}$, $C_{\text{Load}}=1\text{nF}$, $V_{\text{CC}}=3.3\text{V}/5\text{V}$

Characteristic	Symbol	Test Conditions	Min	Typ	Max	Unit
Supply Voltage	V_{CC}	Operating , SC8450XXX-XXX3	3	3.3	3.6	V
		Operating , SC8460XXX-XXX5	4.5	5.0	5.5	V
Supply Current	I_{CC}	$V_{\text{CC}} = 4.5\sim 5.5\text{V}$, output open		22		mA
		$V_{\text{CC}} = 3\sim 3.6\text{V}$, output open		15		mA
Output Resistive Load	R_{L}	Between VIOUT and GND	2			k Ω
VREF Resistive Load	R_{LREF}	Between VREF and GND	2			k Ω
Anti-external magnetic interference suppression ratio	CMFR	The external interference magnetic field perpendicular to the chip surface		-36		dB
Primary Conductor Resistance	R_{PRIMARY}	$T_A = 25^{\circ}\text{C}$		0.24		m Ω
Temperature Coefficient of Primary Conductor Resistance	TCR	$T_A=-40\sim 125^{\circ}\text{C}$		3421		ppm/ $^{\circ}\text{C}$
Hysteresis Voltage	V_{hys}	Viout(IP to +40A then return to 0A)- Viout(IP to -40A, then return to 0A)		1		mV
Rise time	t_{r}	IP=50A/uS		2.08		μS
Propagation Delay	t_{pd}	IP=50A/uS		1.15		μS
Response Time	t_{response}	IP=50A/uS		1.82	2	μS
Bandwidth	f	Small-signal -3 dB,		240		kHz
Noise	I_{N}	BW=240KHz		38.7		mA(rms)
		BW=10KHz		6		mA(rms)
		BW=1KHz		2		mA(rms)
Nonlinearity	E_{LIN}	-100A<IP<100A			1	%
Bidirectional Quiescent Output(suitable for product with suffix B3)	S_{coef}	$V_{\text{CC}}=3.3\text{V}$, $S_{\text{coef}}=\text{Sens}(V_{\text{CC}})/\text{Sens}(3.3\text{V})$		$V_{\text{CC}}/3.3$		
Bidirectional Quiescent Output(suitable for product with suffix B5)	$S_{\text{coef_B5}}$	$V_{\text{CC}}=5.0\text{V}$, $S_{\text{coef}}=\text{Sens}(V_{\text{CC}})/\text{Sens}(5\text{V})$		$V_{\text{CC}}/5$		
VIOUT Linear Rail to Rail Output Range	Vrail-rail	$R_{\text{L}}=4.7\text{k}\Omega$	10		90	%VCC
Power-On Time	t_{PO}	Output reaches steady state level, $T_J = 25^{\circ}\text{C}$		150		μS

Up to 150A, High Accuracy Current Sensor with Adjustable Over Current Fault Detection Current Sensor IC

FLAG overcurrent detection of electrical parameters

Note1: Over full range of TA=25°C, C_{Bypass}=0.47uF, C_{Load}=1.0nF, R_{pu}=10kΩ, V_{CC}=3.3/5V

Note 2: Whether FLAG_S or FLAG_F sets the trigger threshold current, it is recommended that the actual loaded effective current is 1.15*I_{FLAG}

Characteristic	Symbol	Test Conditions	Min	Typ	Max	Unit
Overcurrent detection of electrical parameters						
OC_SET external input range	V _{OC_SET}	OC_SET input voltage	0		V _{CC}	V
OC_SET PIN input current	I _{IN}	High impedance, pin input current			8	uA
Fault output low voltage	V _{FLAG}	R _{PU} =10kΩ	0		0.5	V
FLAG_F built-in fault range	I _{FLAG (F)}	Supported built-in multiples (I _{PR} =peak current) , See the corresponding model Settings for details		0.75*IPR~2*IPR		A
FLAG_S adjustable fault range ^[1]	I _{FLAG (S)}	OC_SET ∈ (0.3*V _{CC} , 0.34*V _{CC})		IPR*0.75		A
		OC_SET ∈ (0.41*V _{CC} , 0.45*V _{CC})		IPR*1		A
		OC_SET ∈ (0.55*V _{CC} , 0.59*V _{CC})		IPR*1.25		A
		OC_SET ∈ (0.65*V _{CC} , 0.71*V _{CC})		IPR*1.5		A
		OC_SET ∈ (0.79*V _{CC} , 0.83*V _{CC})		IPR*1.75		A
		OC_SET ∈ (0.91*V _{CC} , 0.97*V _{CC})		IPR*2		A
FLAG_F restore the threshold point ^[2]	I _{RE}	Current drops to I _{RE} until V _{FLAG} returns to high level		50%*I _{FLAG}		A
FLAG_S restore the threshold point ^[2]				50%*I _{FLAG}		A
FLAG_F back difference value	I _{HYS}	I _{HYS} = I _{FLAG} -I _{RE}		50%*I _{FLAG}		A
FLAG_S back difference value				50%*I _{FLAG}		A
Dynamic response characteristics of overcurrent detection						
fault clearance time	T _{CF}	The time from the IP address falling below I _{FLAG} -I _{HYS} to the time when V _{FLAG} is pulled above V _{FLAG} ; R _{PU} =10 kΩ		3		uS
FLAG output response time ^[3]	T _R	R _{PU} =10kΩ When the current step jumps to I _{FLAG} *1.15, the response time between FLAG < V _{FLAG}		1.5	2	uS
FLAG_F output hold time ^[4]	T _{HOLD (FLAG_F)}	FLAG_F output continues to pull down time		10		uS
Extra duration of current ^[4]	T _{MASK (FLAG_S)}	There must be time to determine the fault and reduce interference and false triggering		3		uS
FLAG_S output hold time ^[4]	T _{HOLD (FLAG_S)}	FLAG_S output continues to pull down time		10		uS

[1] The relationship between the threshold setting of FLAG_S and the overcurrent trigger point is set in STEP mode to prevent false trigger. The overcurrent trigger point is determined by the voltage obtained by OC_SET, not the resistance value, as described in the section "OC_SET Pin Relationship with FLAG_S".

[2] If the absolute value of the IP is higher than I_{FLAG (S)} or I_{FLAG (F)}, the internal fault comparator will trip. The IP must be lower than the I_{RE} before the internal fault comparator will reset.

[3] Response time: It is recommended to obtain the response time <1.5uS when the actual loading current is I_{FLAG}*1.15

[4] In order to ignore the false triggering of the interference current pulse in the application, the FLAG_S trigger condition requires that the primary input current should remain 3uS after the Tr time, which can be simply understood as the total duration of the primary current: T_T+T_{MASK}

[4] Factory shipment defaultMask=0uS, The function is disabled

[2/3/4] Design guaranteee

Up to 150A, High Accuracy Current Sensor with Adjustable
Over Current Fault Detection Current Sensor IC

SC8450A1FT-100B3 Individual Performance Characteristics

Note: Over full range of $T_A = -25^\circ\text{C}$, $C_{\text{Bypass}}=0.47\mu\text{F}$, $C_{\text{Load}}=1\text{nF}$, $V_{\text{CC}}=3.3\text{V}$

Parameter	Symbol	Test Conditions	Min	Typ ^[1]	Max	Unit
NOMINAL PERFORMANCE (Regardless of life time drift error)						
Current-Sensing Range	I_{PR}		-100		100	A
$I_{\text{P}}=0\text{A}$, V_{IOUT} output voltage	V_{OQ}	$I_{\text{P}}=0\text{A}$		$0.5V_{\text{CC}}$		V
VREF output voltage	V_{ref}	Independent of the I_{P} input current		$0.5V_{\text{CC}}$		V
Sensitivity	Sens	$-100\text{A} < I_{\text{P}} < 100\text{A}$		13.2		mV/A
Built-in flow threshold range	$\text{FLAG}_{(\text{IF})}$	Built-in overcurrent threshold (Built-in 10)		125		A
Low speed overflow threshold range ^[2]	$\text{FLAG}_{(\text{IS})}$	Min= $I_{\text{PR}} * 0.75$, Max= $I_{\text{PR}} * 2$	75		200	A
ACCURACY PERFORMANCE						
Sensitivity Error	E_{SENS}	$I_{\text{PR}} = \pm 100\text{A}$, $T_A = 25^\circ\text{C}$		± 1.5		%
		$I_{\text{PR}} = \pm 100\text{A}$, $T_A = 25\sim 125^\circ\text{C}$		± 2.5		%
		$I_{\text{PR}} = \pm 100\text{A}$, $T_A = -40\sim 25^\circ\text{C}$		± 2.5		%
Single output zero error	E_{VOQ}	$I_{\text{P}}=0\text{A}$, $T_A = 25^\circ\text{C}$		± 12		mV
		$I_{\text{P}}=0\text{A}$, $T_A = 25\sim 125^\circ\text{C}$		± 15		mV
		$I_{\text{P}}=0\text{A}$, $T_A = -40\sim 25^\circ\text{C}$		± 15		mV
Differential Output zero Error	E_{VOE}	$I_{\text{P}}=0\text{A}$, $T_A = 25^\circ\text{C}$		± 10		mV
		$I_{\text{P}}=0\text{A}$, $T_A = 25\sim 125^\circ\text{C}$		± 15		mV
		$I_{\text{P}}=0\text{A}$, $T_A = -40\sim 25^\circ\text{C}$		± 15		mV
TOTAL OUTPUT ERROR COMPONENTS : $E_{\text{TOT}} = \{[V_{\text{IOUT_ideal}}(I_{\text{PR}}) - V_{\text{IOUT}}(I_{\text{PR}})]/[Sens_{\text{ideal}} * I_{\text{PR}}]\} * 100\%$						
Total Output Error	E_{TOT}	$I_{\text{PR}} = \pm 100\text{A}$, $T_A = 25^\circ\text{C}$		± 1.5		%
		$I_{\text{PR}} = \pm 100\text{A}$, $T_A = 25^\circ\text{C} \sim 125^\circ\text{C}$		± 2		%
		$I_{\text{PR}} = \pm 100\text{A}$, $T_A = -40^\circ\text{C} \sim 25^\circ\text{C}$		± 3		%
Accuracy of overcurrent fault threshold						
Built-in fault output	$E_{\text{IFLAG_F}}$	$T_A = 25^\circ\text{C}$		± 15		%
		$T_A = -40^\circ\text{C} \sim 125^\circ\text{C}$		± 25		%
Adjustable fault output	$E_{\text{IFLAG_S}}$	$I_{\text{PR}} * 2$, $T_A = 25^\circ\text{C}$		± 15		%
		$I_{\text{PR}} * 2$, $T_A = -40^\circ\text{C} \sim 125^\circ\text{C}$		± 25		%

[1] The typical value is +/-1 sigma, and 68.27% of products fall within this range; The maximum/minimum value is +/-3 sigma value, and 99.73% of products fall within this range

[2] For details about the relationship between the IFLAG_S overcurrent trigger threshold and OC_SET, see "The Relationship between OC_SET Pins and FLAG_S".

Up to 150A, High Accuracy Current Sensor with Adjustable
Over Current Fault Detection Current Sensor IC

SC8450A1FT-150B3 Individual Performance Characteristics

Note: Over full range of $T_A = -25^{\circ}\text{C}$, $C_{\text{Bypass}}=0.47\mu\text{F}$, $C_{\text{Load}}=1\text{nF}$, $V_{\text{CC}}=3.3\text{V}$

Parameter	Symbol	Test Conditions	Min	Typ ^[1]	Max	Unit
NOMINAL PERFORMANCE (Regardless of life time drift error)						
Current-Sensing Range	I_{PR}		-150		150	A
$I_{\text{P}}=0\text{A}$, V_{IOOUT} output voltage	V_{OQ}	$I_{\text{P}}=0\text{A}$		$0.5V_{\text{CC}}$		V
V_{REF} output voltage	V_{ref}	Independent of the I_{P} input current		$0.5V_{\text{CC}}$		V
Sensitivity	Sens	$-150\text{A} < I_{\text{P}} < 150\text{A}$		8.8		mV/A
Built-in flow threshold range	$\text{FLAG}_{(\text{IF})}$	Built-in overcurrent threshold (Built-in 10)		187.5		A
Low speed overflow threshold range ^[2]	$\text{FLAG}_{(\text{IS})}$	Min= $I_{\text{PR}} * 0.75$, Max= $I_{\text{PR}} * 2$	112.5		300	A
ACCURACY PERFORMANCE						
Sensitivity Error	E_{SENS}	$I_{\text{PR}} = \pm 150\text{A}$, $T_A = 25^{\circ}\text{C}$		± 1.5		%
		$I_{\text{PR}} = \pm 150\text{A}$, $T_A = 25 \sim 125^{\circ}\text{C}$		± 2		%
		$I_{\text{PR}} = \pm 150\text{A}$, $T_A = -40 \sim 25^{\circ}\text{C}$		± 2.5		%
Single output zero error	E_{VOQ}	$I_{\text{P}}=0\text{A}$, $T_A = 25^{\circ}\text{C}$		± 10		mV
		$I_{\text{P}}=0\text{A}$, $T_A = 25 \sim 125^{\circ}\text{C}$		± 15		mV
		$I_{\text{P}}=0\text{A}$, $T_A = -40 \sim 25^{\circ}\text{C}$		± 15		mV
Differential Output zero Error	E_{VOE}	$I_{\text{P}}=0\text{A}$, $T_A = 25^{\circ}\text{C}$		± 10		mV
		$I_{\text{P}}=0\text{A}$, $T_A = 25 \sim 125^{\circ}\text{C}$		± 15		mV
		$I_{\text{P}}=0\text{A}$, $T_A = -40 \sim 25^{\circ}\text{C}$		± 15		mV
TOTAL OUTPUT ERROR COMPONENTS : $E_{\text{TOT}} = \{[V_{\text{IOOUT_ideal}}(I_{\text{PR}}) - V_{\text{IOOUT}}(I_{\text{PR}})]/[Sens_{\text{ideal}} * I_{\text{PR}}]\} * 100\%$						
Total Output Error	E_{TOT}	$I_{\text{PR}} = \pm 150\text{A}$, $T_A = 25^{\circ}\text{C}$		± 2		%
		$I_{\text{PR}} = \pm 150\text{A}$, $T_A = 25^{\circ}\text{C} \sim 125^{\circ}\text{C}$		± 2		%
		$I_{\text{PR}} = \pm 150\text{A}$, $T_A = -40^{\circ}\text{C} \sim 25^{\circ}\text{C}$		± 3		%
Accuracy of overcurrent fault threshold						
Built-in fault output	$E_{\text{IFLAG_F}}$	$T_A = 25^{\circ}\text{C}$		± 15		%
		$T_A = -40^{\circ}\text{C} \sim 125^{\circ}\text{C}$		± 25		%
Adjustable fault output	$E_{\text{IFLAG_S}}$	$I_{\text{PR}} * 2$, $T_A = 25^{\circ}\text{C}$		± 15		%
		$I_{\text{PR}} * 2$, $T_A = -40^{\circ}\text{C} \sim 125^{\circ}\text{C}$		± 25		%

[1] The typical value is +/-1 sigma, and 68.27% of products fall within this range; The maximum/minimum value is +/-3 sigma value, and 99.73% of products fall within this range

[2] For details about the relationship between the IFLAG_S overcurrent trigger threshold and OC_SET, see "The Relationship between OC_SET Pins and FLAG_S".

Up to 150A, High Accuracy Current Sensor with Adjustable
Over Current Fault Detection Current Sensor IC

SC8450A1FT-50F3 Individual Performance Characteristics

Note: Over full range of $T_A = -25^{\circ}\text{C}$, $C_{\text{Bypass}}=0.47\mu\text{F}$, $C_{\text{Load}}=1\text{nF}$, $V_{\text{CC}}=3.3\text{V}$

Parameter	Symbol	Test Conditions	Min	Typ ^[1]	Max	Unit
NOMINAL PERFORMANCE (Regardless of life time drift error)						
Current-Sensing Range	I_{PR}		-50		50	A
$I_{\text{P}}=0\text{A}$, V_{IOOUT} output voltage	V_{OQ}	$I_{\text{P}}=0\text{A}$		1.65		V
V_{REF} output voltage	V_{ref}	Independent of the I_{P} input current		1.65		V
Sensitivity	Sens	$-50\text{A} < I_{\text{P}} < 50\text{A}$		26.4		mV/A
Built-in flow threshold range	$\text{FLAG}_{(\text{IF})}$	Built-in overcurrent threshold (Built-in 10)		62.5		A
Low speed overflow threshold range ^[2]	$\text{FLAG}_{(\text{IS})}$	Min= $I_{\text{PR}} * 0.75$, Max= $I_{\text{PR}} * 2$	37.5		100	A
ACCURACY PERFORMANCE						
Sensitivity Error	E_{SENS}	$I_{\text{PR}} = \pm 50\text{A}$, $T_A = 25^{\circ}\text{C}$		± 1.5		%
		$I_{\text{PR}} = \pm 50\text{A}$, $T_A = 25 \sim 125^{\circ}\text{C}$		± 2		%
		$I_{\text{PR}} = \pm 50\text{A}$, $T_A = -40 \sim 25^{\circ}\text{C}$		± 2.5		%
Single output zero error	E_{VOQ}	$I_{\text{P}}=0\text{A}$, $T_A = 25^{\circ}\text{C}$		± 10		mV
		$I_{\text{P}}=0\text{A}$, $T_A = 25 \sim 125^{\circ}\text{C}$		± 15		mV
		$I_{\text{P}}=0\text{A}$, $T_A = -40 \sim 25^{\circ}\text{C}$		± 15		mV
Differential Output zero Error	E_{VOE}	$I_{\text{P}}=0\text{A}$, $T_A = 25^{\circ}\text{C}$		± 10		mV
		$I_{\text{P}}=0\text{A}$, $T_A = 25 \sim 125^{\circ}\text{C}$		± 15		mV
		$I_{\text{P}}=0\text{A}$, $T_A = -40 \sim 25^{\circ}\text{C}$		± 15		mV
TOTAL OUTPUT ERROR COMPONENTS : $E_{\text{TOT}} = \{[V_{\text{IOOUT_ideal}}(I_{\text{PR}}) - V_{\text{IOOUT}}(I_{\text{PR}})]/[Sens_{\text{ideal}} * I_{\text{PR}}]\} * 100\%$						
Total Output Error	E_{TOT}	$I_{\text{PR}} = \pm 50\text{A}$, $T_A = 25^{\circ}\text{C}$		± 2		%
		$I_{\text{PR}} = \pm 50\text{A}$, $T_A = 25^{\circ}\text{C} \sim 125^{\circ}\text{C}$		± 2		%
		$I_{\text{PR}} = \pm 50\text{A}$, $T_A = -40^{\circ}\text{C} \sim 25^{\circ}\text{C}$		± 3		%
Accuracy of overcurrent fault threshold						
Built-in fault output	$E_{\text{IFLAG_F}}$	$T_A = 25^{\circ}\text{C}$		± 15		%
		$T_A = -40^{\circ}\text{C} \sim 125^{\circ}\text{C}$		± 25		%
Adjustable fault output	$E_{\text{IFLAG_S}}$	$I_{\text{PR}} * 2$, $T_A = 25^{\circ}\text{C}$		± 15		%
		$I_{\text{PR}} * 2$, $T_A = -40^{\circ}\text{C} \sim 125^{\circ}\text{C}$		± 25		%

[1] The typical value is +/-1 sigma, and 68.27% of products fall within this range; The maximum/minimum value is +/-3 sigma value, and 99.73% of products fall within this range

[2] For details about the relationship between the IFLAG_S overcurrent trigger threshold and OC_SET, see "The Relationship between OC_SET Pins and FLAG_S".

Up to 150A, High Accuracy Current Sensor with Adjustable
Over Current Fault Detection Current Sensor IC

SC8460A1FT-50F5 Individual Performance Characteristics

Note: Over full range of $T_A = -25^{\circ}\text{C}$, $C_{\text{Bypass}}=0.47\mu\text{F}$, $C_{\text{Load}}=1\text{nF}$, $V_{\text{CC}}=3.3\text{V}$

Parameter	Symbol	Test Conditions	Min	Typ ^[1]	Max	Unit
NOMINAL PERFORMANCE (Regardless of life time drift error)						
Current-Sensing Range	I_{PR}		-50		50	A
$I_{\text{P}}=0\text{A}$, V_{IOOUT} output voltage	V_{OQ}	$I_{\text{P}}=0\text{A}$		2.5		V
VREF output voltage	V_{ref}	Independent of the I_{P} input current		2.5		V
Sensitivity	Sens	$-50\text{A} < I_{\text{P}} < 50\text{A}$		40		mV/A
Built-in flow threshold range	FLAG(IF)	Built-in overcurrent threshold (Built-in 10)		62.5		A
Low speed overflow threshold range ^[2]	FLAG (IS)	Min= $I_{\text{PR}} * 0.75$, Max= $I_{\text{PR}} * 2$	37.5		100	A
ACCURACY PERFORMANCE						
Sensitivity Error	E_{SENS}	$I_{\text{PR}} = \pm 50\text{A}$, $T_A = 25^{\circ}\text{C}$		± 1.5		%
		$I_{\text{PR}} = \pm 50\text{A}$, $T_A = 25 \sim 125^{\circ}\text{C}$		± 2		%
		$I_{\text{PR}} = \pm 50\text{A}$, $T_A = -40 \sim 25^{\circ}\text{C}$		± 2.5		%
Single output zero error	E_{VOQ}	$I_{\text{P}}=0\text{A}$, $T_A = 25^{\circ}\text{C}$		± 10		mV
		$I_{\text{P}}=0\text{A}$, $T_A = 25 \sim 125^{\circ}\text{C}$		± 15		mV
		$I_{\text{P}}=0\text{A}$, $T_A = -40 \sim 25^{\circ}\text{C}$		± 15		mV
Differential Output zero Error	E_{VOE}	$I_{\text{P}}=0\text{A}$, $T_A = 25^{\circ}\text{C}$		± 10		mV
		$I_{\text{P}}=0\text{A}$, $T_A = 25 \sim 125^{\circ}\text{C}$		± 15		mV
		$I_{\text{P}}=0\text{A}$, $T_A = -40 \sim 25^{\circ}\text{C}$		± 15		mV
TOTAL OUTPUT ERROR COMPONENTS : $E_{\text{TOT}} = \{[V_{\text{IOOUT_ideal}}(I_{\text{PR}}) - V_{\text{IOOUT}}(I_{\text{PR}})]/[Sens_{\text{ideal}} * I_{\text{PR}}]\} * 100\%$						
Total Output Error	E_{TOT}	$I_{\text{PR}} = \pm 50\text{A}$, $T_A = 25^{\circ}\text{C}$		± 2		%
		$I_{\text{PR}} = \pm 50\text{A}$, $T_A = 25^{\circ}\text{C} \sim 125^{\circ}\text{C}$		± 2		%
		$I_{\text{PR}} = \pm 50\text{A}$, $T_A = -40^{\circ}\text{C} \sim 25^{\circ}\text{C}$		± 3		%
Accuracy of overcurrent fault threshold						
Built-in fault output	$E_{\text{IFLAG_F}}$	$T_A = 25^{\circ}\text{C}$		± 15		%
		$T_A = -40^{\circ}\text{C} \sim 125^{\circ}\text{C}$		± 25		%
Adjustable fault output	$E_{\text{IFLAG_S}}$	$I_{\text{PR}} * 2$, $T_A = 25^{\circ}\text{C}$		± 15		%
		$I_{\text{PR}} * 2$, $T_A = -40^{\circ}\text{C} \sim 125^{\circ}\text{C}$		± 25		%

[1] The typical value is +/-1 sigma, and 68.27% of products fall within this range; The maximum/minimum value is +/-3 sigma value, and 99.73% of products fall within this range

[2] For details about the relationship between the IFLAG_S overcurrent trigger threshold and OC_SET, see "The Relationship between OC_SET Pins and FLAG_S".

Up to 150A, High Accuracy Current Sensor with Adjustable
Over Current Fault Detection Current Sensor IC

SC8460A1FT-50B5 Individual Performance Characteristics

Note: Over full range of $T_A = -25^{\circ}\text{C}$, $C_{\text{Bypass}}=0.47\mu\text{F}$, $C_{\text{Load}}=1\text{nF}$, $V_{\text{CC}}=3.3\text{V}$

Parameter	Symbol	Test Conditions	Min	Typ ^[1]	Max	Unit
NOMINAL PERFORMANCE (Regardless of life time drift error)						
Current-Sensing Range	I_{PR}		-50		50	A
$I_{\text{P}}=0\text{A}$, V_{IOUT} output voltage	V_{OQ}	$I_{\text{P}}=0\text{A}$		0.5Vcc		V
VREF output voltage	V_{ref}	Independent of the IP input current		0.5Vcc		V
Sensitivity	Sens	$-50\text{A} < I_{\text{P}} < 50\text{A}$		40		mV/A
Built-in flow threshold range	FLAG(IF)	Built-in overcurrent threshold (Built-in 10)		62.5		A
Low speed overflow threshold range ^[2]	FLAG (IS)	Min= $I_{\text{PR}} * 0.75$, Max= $I_{\text{PR}} * 2$	37.5		100	A
ACCURACY PERFORMANCE						
Sensitivity Error	E_{SENS}	$I_{\text{PR}} = \pm 50\text{A}$, $T_A = 25^{\circ}\text{C}$		± 1.5		%
		$I_{\text{PR}} = \pm 50\text{A}$, $T_A = 25 \sim 125^{\circ}\text{C}$		± 2		%
		$I_{\text{PR}} = \pm 50\text{A}$, $T_A = -40 \sim 25^{\circ}\text{C}$		± 2.5		%
Single output zero error	E_{VOQ}	$I_{\text{P}}=0\text{A}$, $T_A = 25^{\circ}\text{C}$		± 10		mV
		$I_{\text{P}}=0\text{A}$, $T_A = 25 \sim 125^{\circ}\text{C}$		± 15		mV
		$I_{\text{P}}=0\text{A}$, $T_A = -40 \sim 25^{\circ}\text{C}$		± 15		mV
Differential Output zero Error	E_{VOE}	$I_{\text{P}}=0\text{A}$, $T_A = 25^{\circ}\text{C}$		± 10		mV
		$I_{\text{P}}=0\text{A}$, $T_A = 25 \sim 125^{\circ}\text{C}$		± 15		mV
		$I_{\text{P}}=0\text{A}$, $T_A = -40 \sim 25^{\circ}\text{C}$		± 15		mV
TOTAL OUTPUT ERROR COMPONENTS : $E_{\text{TOT}} = \{[V_{\text{IOUT_ideal}}(I_{\text{PR}}) - V_{\text{IOUT}}(I_{\text{PR}})]/[Sens_{\text{ideal}} * I_{\text{PR}}]\} * 100\%$						
Total Output Error	E_{TOT}	$I_{\text{PR}} = \pm 50\text{A}$, $T_A = 25^{\circ}\text{C}$		± 2		%
		$I_{\text{PR}} = \pm 50\text{A}$, $T_A = 25^{\circ}\text{C} \sim 125^{\circ}\text{C}$		± 2		%
		$I_{\text{PR}} = \pm 50\text{A}$, $T_A = -40^{\circ}\text{C} \sim 25^{\circ}\text{C}$		± 3		%
Accuracy of overcurrent fault threshold						
Built-in fault output	$E_{\text{IFLAG_F}}$	$T_A = 25^{\circ}\text{C}$		± 15		%
		$T_A = -40^{\circ}\text{C} \sim 125^{\circ}\text{C}$		± 25		%
Adjustable fault output	$E_{\text{IFLAG_S}}$	$I_{\text{PR}} * 2$, $T_A = 25^{\circ}\text{C}$		± 15		%
		$I_{\text{PR}} * 2$, $T_A = -40^{\circ}\text{C} \sim 125^{\circ}\text{C}$		± 25		%

[1] The typical value is +/-1 sigma, and 68.27% of products fall within this range; The maximum/minimum value is +/-3 sigma value, and 99.73% of products fall within this range

[2] For details about the relationship between the IFLAG_S overcurrent trigger threshold and OC_SET, see "The Relationship between OC_SET Pins and FLAG_S".

*Up to 150A, High Accuracy Current Sensor with Adjustable
Over Current Fault Detection Current Sensor IC*

SC8460A1FT-100B5 Individual Performance Characteristics

 Note: Over full range of $T_A = -25^{\circ}\text{C}$, $C_{\text{Bypass}}=0.47\mu\text{F}$, $C_{\text{Load}}=1\text{nF}$, $V_{\text{CC}}=5\text{V}$

Parameter	Symbol	Test Conditions	Min	Typ ^[1]	Max	Unit
NOMINAL PERFORMANCE (Regardless of life time drift error)						
Current-Sensing Range	I_{PR}		-100		100	A
IP=0A, VIOUT output voltage	V_{OQ}	IP=0A		0.5V _{CC}		V
VREF output voltage	V_{ref}	Independent of the IP input current		0.5V _{CC}		V
Sensitivity	Sens	-100A<IP<100A		20		mV/A
Built-in flow threshold range	FLAG(I _F)	Built-in overcurrent threshold (Built-in 10)		125		A
Low speed overflow threshold range ^[2]	FLAG (I _S)	Min= $I_{\text{PR}} * 0.75$, Max= $I_{\text{PR}} * 2$	75		200	A
ACCURACY PERFORMANCE						
Sensitivity Error	E_{SENS}	$I_{\text{PR}} = \pm 100\text{ A}$, $T_A = 25^{\circ}\text{C}$		± 1.5		%
		$I_{\text{PR}} = \pm 100\text{ A}$, $T_A = 25\sim 125^{\circ}\text{C}$		± 2		%
		$I_{\text{PR}} = \pm 100\text{ A}$, $T_A = -40\sim 25^{\circ}\text{C}$		± 2.5		%
Single output zero error	E_{VOQ}	$I_{\text{P}}=0\text{A}$, $T_A = 25^{\circ}\text{C}$		± 12		mV
		$I_{\text{P}}=0\text{A}$, $T_A = 25\sim 125^{\circ}\text{C}$		± 15		mV
		$I_{\text{P}}=0\text{A}$, $T_A = -40\sim 25^{\circ}\text{C}$		± 15		mV
Differential Output zero Error	E_{VOE}	$I_{\text{P}}=0\text{A}$, $T_A = 25^{\circ}\text{C}$		± 10		mV
		$I_{\text{P}}=0\text{A}$, $T_A = 25\sim 125^{\circ}\text{C}$		± 15		mV
		$I_{\text{P}}=0\text{A}$, $T_A = -40\sim 25^{\circ}\text{C}$		± 15		mV
TOTAL OUTPUT ERROR COMPONENTS: $E_{\text{TOT}} = \{[V_{\text{IOUT_ideal}}(I_{\text{PR}}) - V_{\text{IOUT}}(I_{\text{PR}})] / [\text{Sens}_{\text{ideal}} * I_{\text{PR}}]\} * 100\%$						
Total Output Error	E_{TOT}	$I_{\text{PR}} = \pm 100\text{ A}$, $T_A = 25^{\circ}\text{C}$		± 1.5		%
		$I_{\text{PR}} = \pm 100\text{ A}$, $T_A = 25^{\circ}\text{C} \sim 125^{\circ}\text{C}$		± 2		%
		$I_{\text{PR}} = \pm 100\text{ A}$, $T_A = -40^{\circ}\text{C} \sim 25^{\circ}\text{C}$		± 3		%
Accuracy of overcurrent fault threshold						
Built-in fault output	$E_{\text{IFLAG_F}}$	$T_A = 25^{\circ}\text{C}$		± 15		%
		$T_A = -40^{\circ}\text{C} \sim 125^{\circ}\text{C}$		± 25		%
Adjustable fault output	$E_{\text{IFLAG_S}}$	$I_{\text{PR}} * 2$, $T_A = 25^{\circ}\text{C}$		± 15		%
		$I_{\text{PR}} * 2$, $T_A = -40^{\circ}\text{C} \sim 125^{\circ}\text{C}$		± 25		%

[1] The typical value is +/-1 sigma, and 68.27% of products fall within this range; The maximum/minimum value is +/-3 sigma value, and 99.73% of products fall within this range

[2] For details about the relationship between the IFLAG_S overcurrent trigger threshold and OC_SET, see "The Relationship between OC_SET Pins and FLAG_S".

Up to 150A, High Accuracy Current Sensor with Adjustable
Over Current Fault Detection Current Sensor IC

SC8460A1FT-150B5 Individual Performance Characteristics

Note: Over full range of $T_A = -25^{\circ}\text{C}$, $C_{\text{Bypass}}=0.47\mu\text{F}$, $C_{\text{Load}}=1\text{nF}$, $V_{\text{CC}}=5\text{V}$

参数名称	参数符号	测试条件	最小值	典型值 ¹	最大值	单位
NOMINAL PERFORMANCE (Regardless of life time drift error)						
Current-Sensing Range	I_{PR}		-150		150	A
IP=0A, VIOUT output voltage	V_{OQ}	IP=0A		$0.5V_{\text{CC}}$		V
VREF output voltage	V_{ref}	Independent of the IP input current		$0.5V_{\text{CC}}$		V
Sensitivity	Sens	$-150\text{A} < \text{IP} < 150\text{A}$		13.33		mV/A
Built-in flow threshold range	FLAG(I_{F})	Built-in overcurrent threshold (Built-in 10)		187.5		A
Low speed overflow threshold range [2]	FLAG (I_{S})	Min= $I_{\text{PR}} * 0.75$, Max= $I_{\text{PR}} * 2$	112.5		300	A
ACCURACY PERFORMANCE						
Sensitivity Error	E_{SENS}	$I_{\text{PR}} = \pm 150\text{ A}, T_A = 25^{\circ}\text{C}$		± 1.5		%
		$I_{\text{PR}} = \pm 150\text{ A}, T_A = 25 \sim 125^{\circ}\text{C}$		± 2		%
		$I_{\text{PR}} = \pm 150\text{ A}, T_A = -40 \sim 25^{\circ}\text{C}$		± 2.5		%
Single output zero error	E_{VOQ}	IP=0A, $T_A = 25^{\circ}\text{C}$		± 10		mV
		IP=0A, $T_A = 25 \sim 125^{\circ}\text{C}$		± 15		mV
		IP=0A, $T_A = -40 \sim 25^{\circ}\text{C}$		± 15		mV
Differential Output zero Error	E_{VOE}	IP=0A, $T_A = 25^{\circ}\text{C}$		± 10		mV
		IP=0A, $T_A = 25 \sim 125^{\circ}\text{C}$		± 15		mV
		IP=0A, $T_A = -40 \sim 25^{\circ}\text{C}$		± 15		mV
TOTAL OUTPUT ERROR COMPONENTS: $E_{\text{TOT}} = \{[V_{\text{IOUT_ideal}}(I_{\text{PR}}) - V_{\text{IOUT}}(I_{\text{PR}})] / [\text{Sens}_{\text{Sideal}} * I_{\text{PR}}]\} * 100\%$						
Total Output Error	E_{TOT}	$I_{\text{PR}} = \pm 150\text{ A}, T_A = 25^{\circ}\text{C}$		± 2		%
		$I_{\text{PR}} = \pm 150\text{ A}, T_A = 25^{\circ}\text{C} \sim 125^{\circ}\text{C}$		± 2		%
		$I_{\text{PR}} = \pm 150\text{ A}, T_A = -40^{\circ}\text{C} \sim 25^{\circ}\text{C}$		± 3		%
Accuracy of overcurrent fault threshold						
Built-in fault output	$E_{\text{IFLAG_F}}$	$T_A = 25^{\circ}\text{C}$		± 15		%
		$T_A = -40^{\circ}\text{C} \sim 125^{\circ}\text{C}$		± 25		%
Adjustable fault output	$E_{\text{IFLAG_S}}$	$I_{\text{PR}} * 2, T_A = 25^{\circ}\text{C}$		± 15		%
		$I_{\text{PR}} * 2, T_A = -40^{\circ}\text{C} \sim 125^{\circ}\text{C}$		± 25		%

[1] The typical value is +/-1 sigma, and 68.27% of products fall within this range; The maximum/minimum value is +/-3 sigma value, and 99.73% of products fall within this range

[2] For details about the relationship between the IFLAG_S overcurrent trigger threshold and OC_SET, see "The Relationship between OC_SET Pins and FLAG_S".

Up to 150A, High Accuracy Current Sensor with Adjustable
Over Current Fault Detection Current Sensor IC

Accuracy Characteristic Curve (SC8450A1FT-100B3)

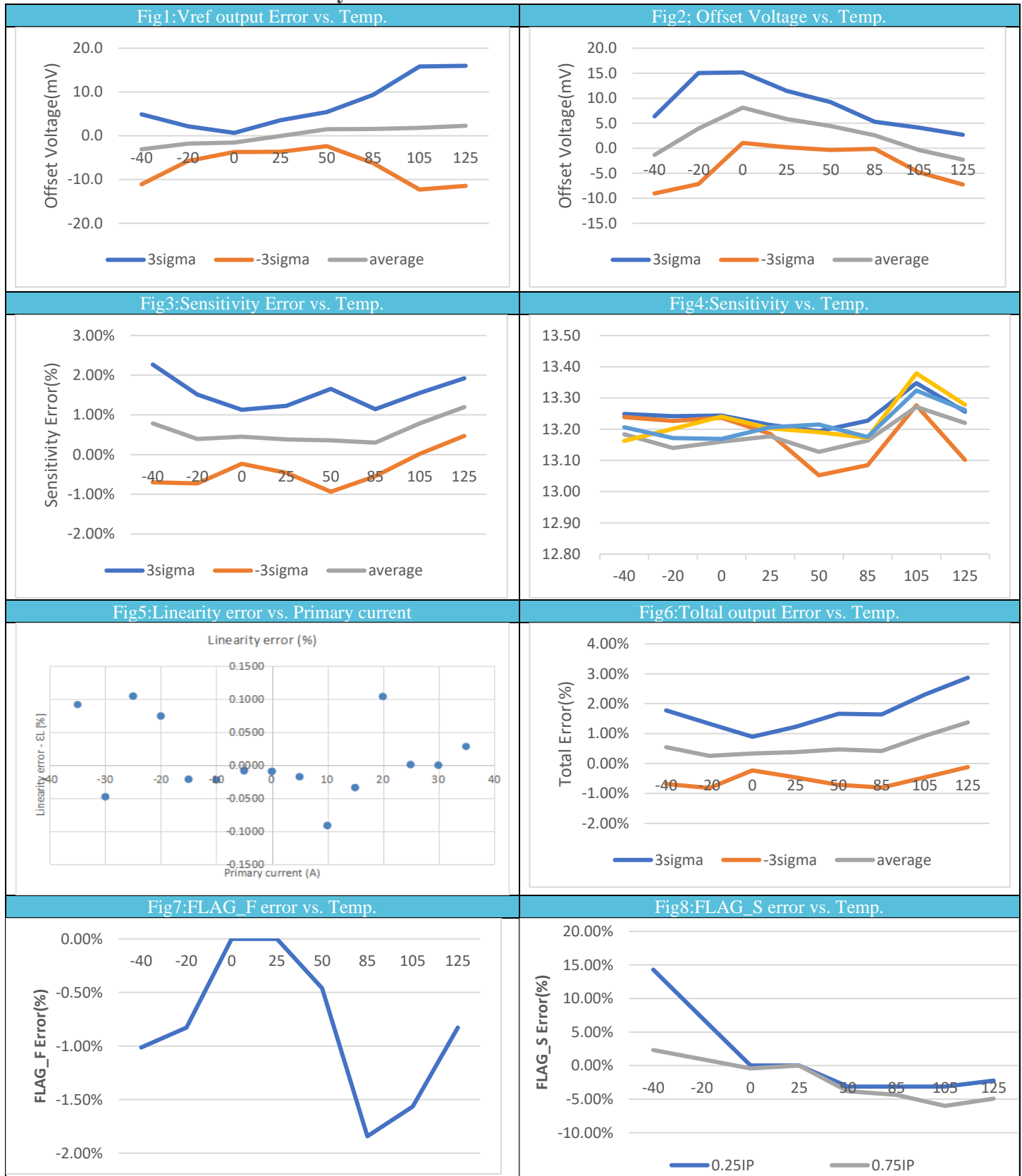

AC/Dynamic characteristic diagram

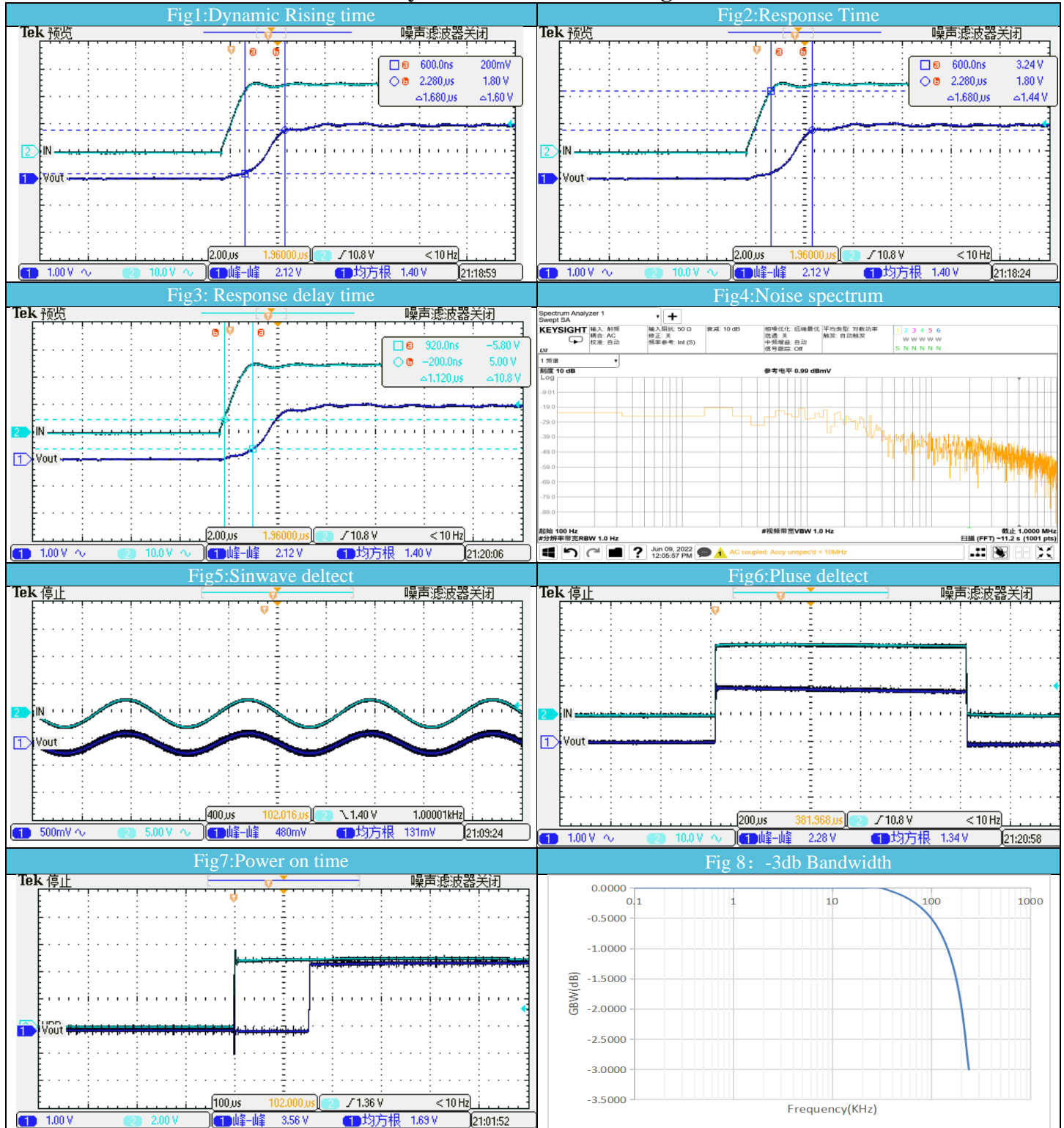

Functional Description

◆ Internal Reference Voltage

Vref is always equal to the static bias output value of VIOUT, that is, VIOUT value when IP=0A.

The relationship between VIOUT and Vref obey that following formula:

$$VIOUT = IP * Sens + Vref,$$

When SC84xxAFT**Fx is used, VREF constantly outputs 2.5V/1.65V, And has a driving capacity of more than 30mA;

When SC84xxAFT**Bx is used, VREF constantly outputs 0.5VCC, And has a driving capacity of more than 30mA;

◆ Overcurrent Function

Description:

With two overcurrent fault comparators:

FLAG_F: When FLAG_F pins are pulled up, the default output is high. When the absolute value of the input current exceeds IPR* multiple, the comparator tripping output is pulled down to low level. This function has a <2uS ultra-fast response time, which is very suitable for detection and verification of short circuit events. The overcurrent must be maintained at least 1uS in order to be detected, and after the detection of the post stage, the output low signal will maintain a residence time of 10uS, so that the controller can easily detect the overcurrent signal.

FLAG_S: After FLAG_S pin is pulled up, the default output is high. When the absolute value of the input current exceeds the set threshold, the comparator tripping output is pulled down to the low level. This function improves the high precision characteristic and is suitable for the detection of overload conditions beyond the range. The overcurrent must be maintained at least 3uS in order to be detected, and after the detection of the post stage, the output low signal will maintain a residence time of 10uS, so that the controller can easily detect the overcurrent signal.

OC_SET: Allows users to set the FLAG_S trip threshold through external voltage dividers. The relationship between OC_SET pins and FLAG_S is shown in the following table:

OC_SET PIN and FLAG_S Relationship

OC_SET input voltage ^[1]	IFLAG_S trigger threshold ^[2]		
	SC8450Axxx-xxBx	SC8460Axxx-xxBx	
VCC= 3.3V and 5V			
OC_SET ∈ (0.3*Vcc, 0.34*Vcc)	IPR*0.75		A
OC_SET ∈ (0.41*Vcc, 0.45*Vcc)	IPR*1		A
OC_SET ∈ (0.55*Vcc, 0.59*Vcc)	IPR*1.25		A
OC_SET ∈ (0.65*Vcc, 0.71*Vcc)	IPR*1.5		A
OC_SET ∈ (0.79*Vcc, 0.83*Vcc)	IPR*1.75		A
OC_SET ∈ (0.91*Vcc, 0.97*Vcc)	IPR*2		A

Up to 150A, High Accuracy Current Sensor with Adjustable Over Current Fault Detection Current Sensor IC

[1] OC_SET function:

- 1) OC_SET input voltage supports $0.3 \cdot V_{CC} \sim 0.97 \cdot V_{CC}$ range, users can set the overcurrent alarm threshold of FLAG_S pin through the OC_SET input voltage (as shown in the above table), the input voltage is allowed to use VCC and resistance partial voltage for adaptive (Figure 1). When the OC_SET input voltage is in the range of $OC_SET \in (0.3 \cdot V_{CC}, 0.34 \cdot V_{CC})$, it corresponds to the minimum trigger point IFLAG; when the OC_SET input voltage is in the range of $OC_SET \in (0.91 \cdot V_{CC}, 0.97 \cdot V_{CC})$, it corresponds to the maximum trigger point IFLAG.
- 2) OC_SET input voltage supports $0.3 \cdot V_{CC} \sim 0.97 \cdot V_{CC}$ range, but it should be noted that it is not a linear selection, but designed into a STEP mode, set into 6 intervals, each interval has an input voltage range to correspond to the IFLAG overcurrent trigger threshold.

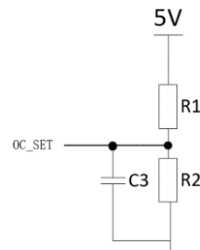

Figure 1: OC SET resistor divider

[2] IFLAG trigger threshold:

Whether FLAG_S or FLAG_F sets the trigger threshold current, it is recommended that the actual loaded effective current is $IFLAG \cdot 1.15$

FLAG output characteristic diagram :

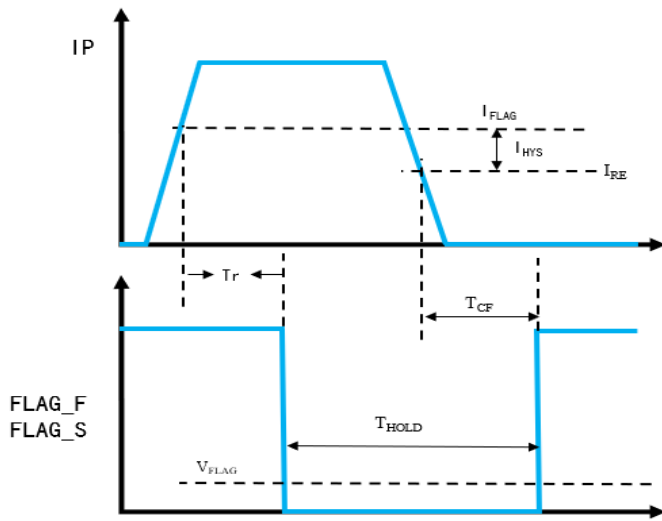

Figure 2: Fault response timing when the Tmask function is disabled

Figure2 The fault feature applies to FLAG_F as well as FLAG_S, which is disabled by Tmask

When the current through the IP exceeds the IFLAG threshold, after the Tr delay time, the FLAG_F fault pin will trip, and the fault will remain active for a period of time until the absolute current is less than the fault threshold (IRE).

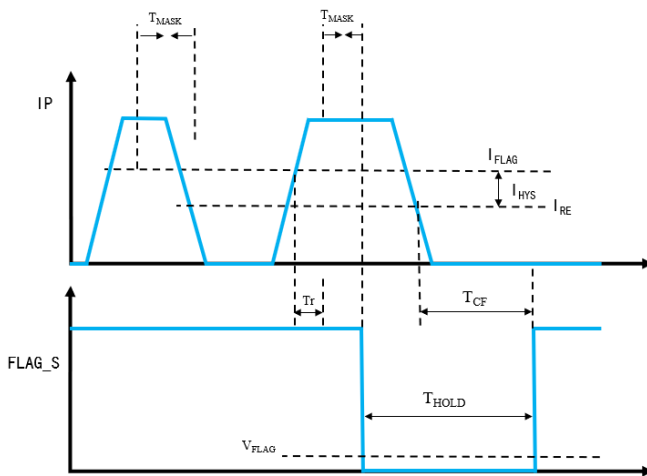

Figure 3: FLAG S timing diagram when Tmsk function is enabled

Figure 3 Fault characteristics apply to FLAG S when the Tmask function is enabled

TMASK is defined as the extra time that the primary side current must be present after the Tr time has passed.

As shown in Figure 3, where the width of the first current transient pulse is smaller than TMASK, the purpose is that if a fault occurs, but the fault duration is smaller than TMASK, the device will not report the fault, which can prevent the wrong alarm caused by the interference signal of the transient current pulse.

When the second current pulse exceeds the IFLAG threshold and after a time of \geq TMASK, the fault is triggered and the output is pulled down, until the absolute current is less than the fault threshold (IRE), the fault will remain active for a period of time until the fault state is over and reset.

Up to 150A, High Accuracy Current Sensor with Adjustable Over Current Fault Detection Current Sensor IC

◆ **Proportional Coefficient Of Sensitivity**

Sensitivity ratio coefficient (sens_coef), which defines the coefficient proportional to the sensitivity and VCC. The ideal coefficient is 1. If the VCC increases by 10%, the sensitivity will increase by 10%. At this time, the coefficient is 1.1, which means that the sensitivity increases by 10% compared with the ideal proportion. The relationship between the scale coefficient is described by the following equation:

$$S_{coef} = Sens_coef = \frac{SENS_{VCC}}{SENS_{VCCN}}$$

It is the ratio of the sensitivity SENS_{VCC} under the supply voltage Vcc to the sensitivity SENS_{VCCN} under the rated supply voltage VCCN. Through this value, we can get the sensitivity under any supply voltage.

In ideal situation:

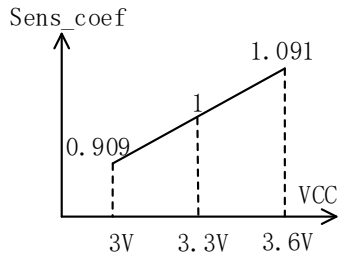

◆ **Proportional Relationship**

Using SC8450_60**B*, sensitivity and zero voltage are changing with VCC proportion, zero for the VCC / 2, sensitivity to SENS_{VCC}* Sens_coef.

Using SC8450_60**F*, sensitivity and zero voltage are changing with VCC proportion, zero for the 0.1VCC, sensitivity to SENS_{VCC}* Sens_coef.

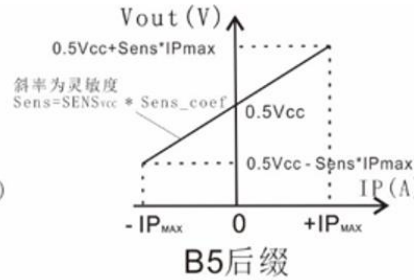
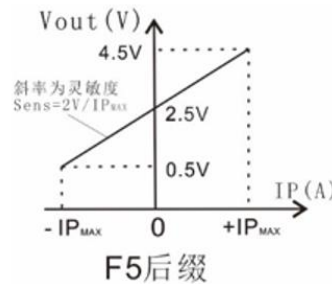

◆ **Impact of External Magnetic Fields**

CMFR is used to express the ability of sensor resisting impact of external magnetic fields. The larger the absolute value of CMFR, the stronger the ability to resist external magnetic interference is.

$$CMFR = 20 \lg \left| \frac{A_{CM}}{Sens/CF} \right|$$

Where CF is the magnetic field coupling factor of the primary current in the sensor, Sens is the sensor sensitivity, and Sens/CF represents the change ratio of the sensor itself in mv/G.

For example: CMFR = -40dB, Sens = 40mv/A, CF = 10G/A, then ACM is 0.04mv/G.

Up to 150A, High Accuracy Current Sensor with Adjustable Over Current Fault Detection Current Sensor IC

◆ **Delay time t_{pd} and Response time $t_{response}$**

Both delay time and response time are used to characterize the time difference between primary side and secondary side;
 The delay time is the time difference when the secondary output reaches 20% of the steady-state output value and the primary output reaches 20% of the steady-state current;
 The response time is the time difference when the secondary output reaches 90% of the steady-state output value and the primary output reaches 90% of the steady-state current.

Rise Time t_r

The rising time is used to represent the time difference of the secondary side itself, that is, the time difference between the time when the output of the secondary side reaches 90% of the steady-state output value and 10% of the steady-state output value.

Power-On Time t_{po}

Power-On Time is defined as the time it takes for the output voltage to settle within $\pm 10\%$ of its steady-state value under an applied magnetic field, after the power supply has reached its minimum specified operating voltage.

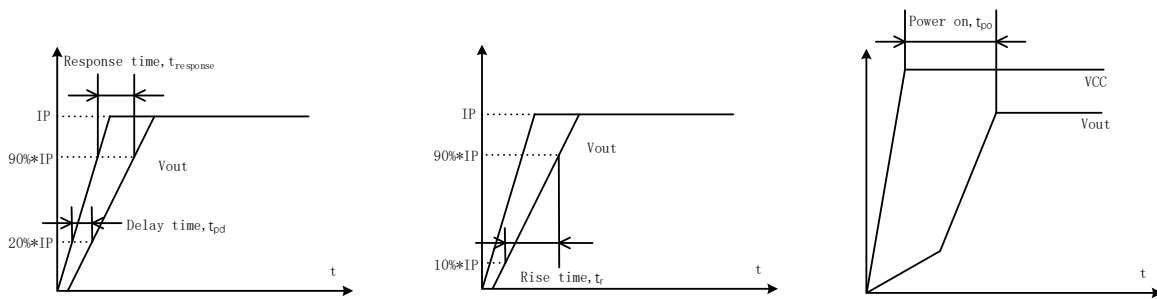

◆ **Thermal resistance $R_{\theta JA}$**

Based on a demo board, the thermal resistance is calculated by measuring the chip top temperature and power value. According to the thermal resistance, the junction temperature can be calculated as a reference. The actual surface temperature measurement value is shown in the relationship between the package temperature and the measured current.

$$T_J = T_A + (R_{\theta JA} * POWER) = T_A + (R_{\theta JA} * IP^2 * R_{PRIMARY});$$

Where T_J is junction temperature and T_A is ambient temperature.

Up to 150A, High Accuracy Current Sensor with Adjustable Over Current Fault Detection Current Sensor IC

◆ Reference application circuit diagram

1. Schematic diagram of connection between SC8450/60 and overcurrent detection

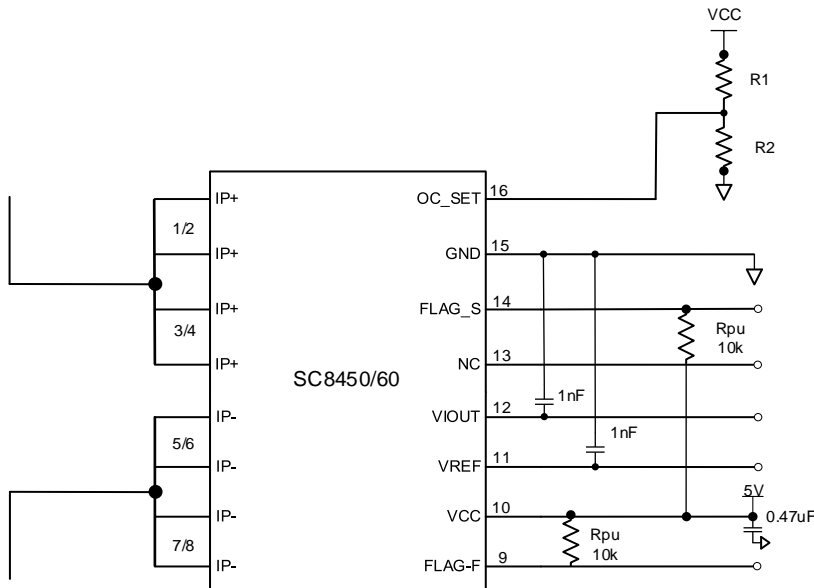

2. SC8450/60 VOUT and VREF Differential application diagram:

As below : $V_{IOUT} = I_P * Sensitivity * (5R / R)$

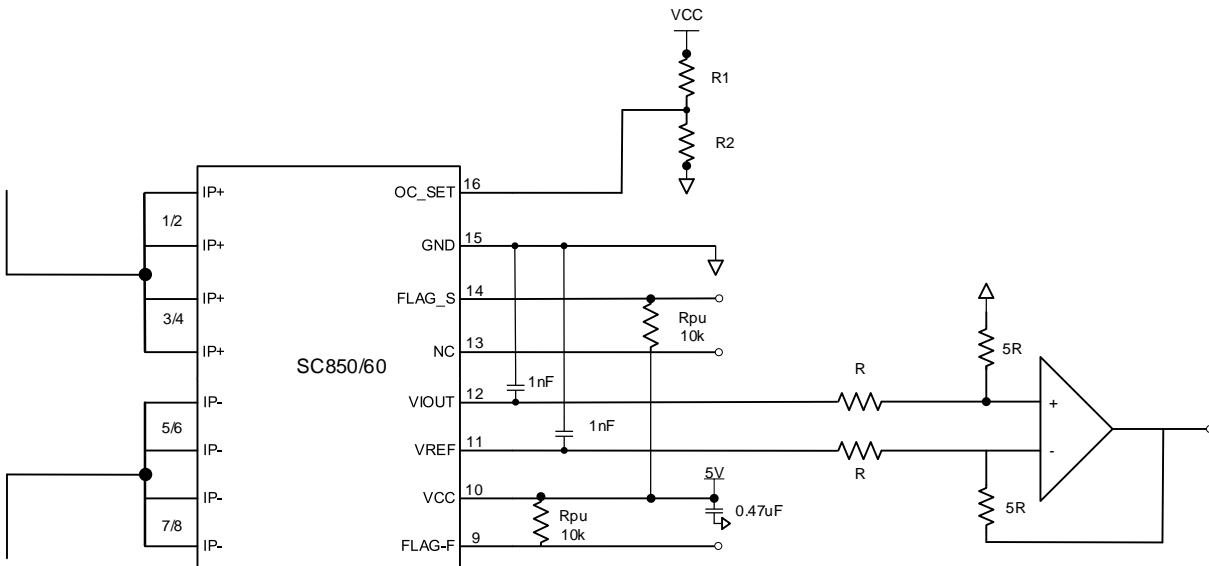

SC8450/SC8460 series

Up to 150A, High Accuracy Current Sensor with Adjustable
Over Current Fault Detection Current Sensor IC

PCB Demo Evaluation Board Layout

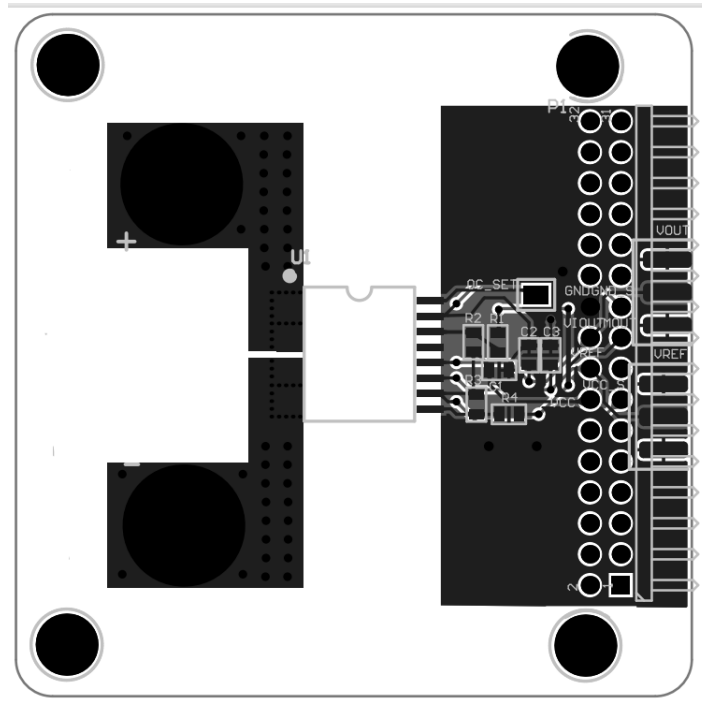

Mark Description

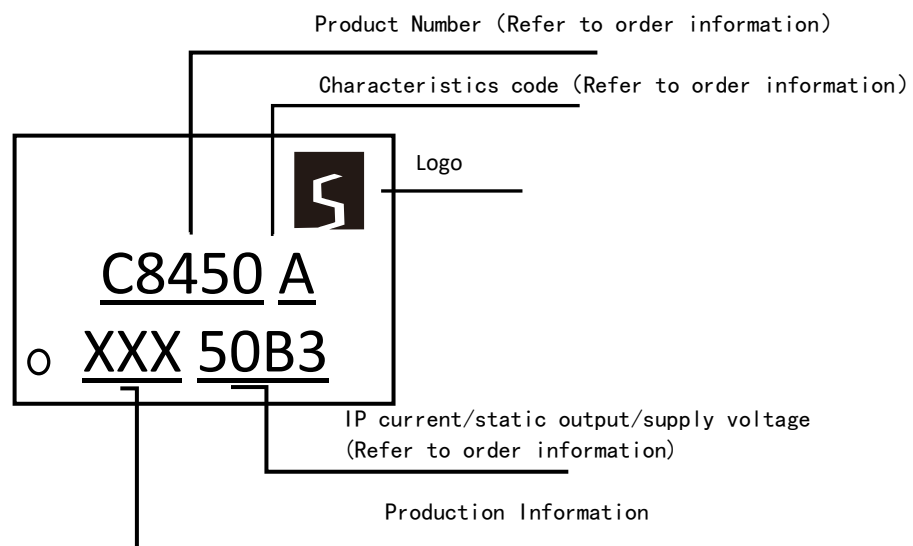

Note: X is non fixed character, defined by SENK SEMI naming rules

SC8450/SC8460 series

Up to 150A, High Accuracy Current Sensor with Adjustable Over Current Fault Detection Current Sensor IC

Package Information

Note: all dimensions are in millimeters.

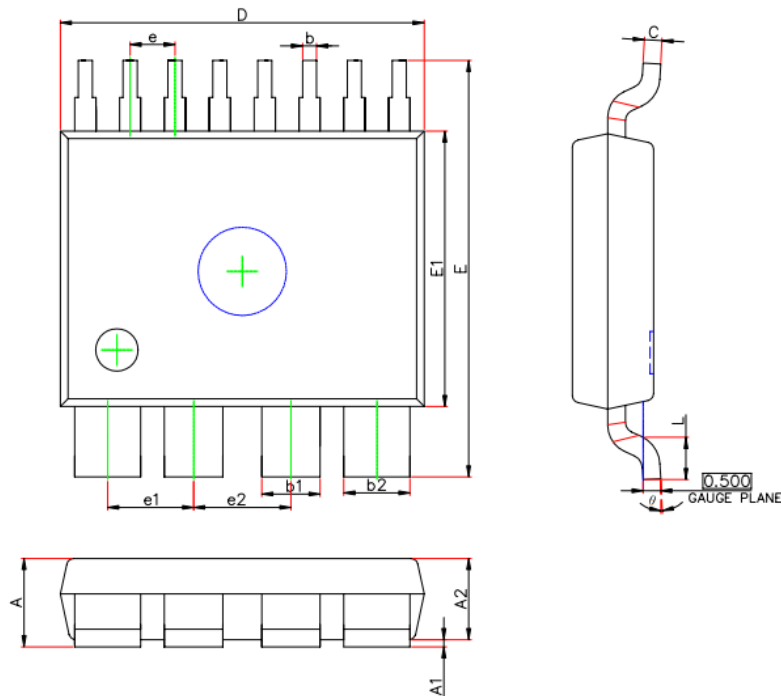

Symbol	Dimensions In Millimeters		Dimensions In Inches	
	Min.	Max.	Min.	Max.
A	-	2.650	-	0.104
A1	0.100	0.300	0.004	0.012
A2	2.250	2.350	0.089	0.093
b	0.350	0.450	0.014	0.018
b1	1.560	1.760	0.061	0.069
b2	1.770	1.970	0.070	0.078
c	0.460	0.540	0.018	0.021
D	10.250	10.350	0.404	0.407
E	11.650	11.950	0.459	0.470
E1	7.750	7.850	0.305	0.309
e	1.270(BSC)		0.050(BSC)	
e1	2.43(BSC)		0.096(BSC)	
e2	2.76(BSC)		0.109(BSC)	
L	1.090	1.290	0.043	0.051
θ	1°	5°	1°	5°

Up to 150A, High Accuracy Current Sensor with Adjustable
Over Current Fault Detection Current Sensor IC

Packing information

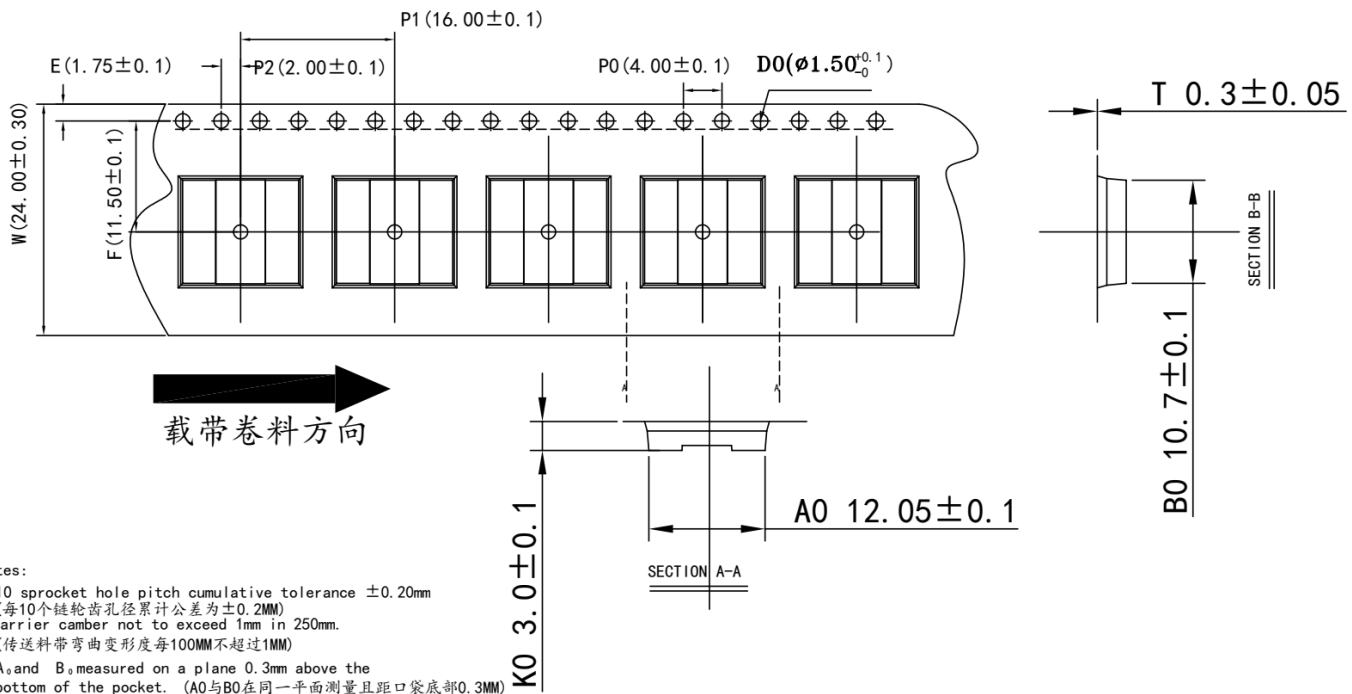

Notes:

1. 10 sprocket hole pitch cumulative tolerance $\pm 0.20\text{mm}$
(每10个链轮齿孔直径累计公差为 $\pm 0.2\text{MM}$)
2. Carrier camber not to exceed 1mm in 250mm.
(传送料带弯曲变形度每100MM不超过1MM)
3. A_0 and B_0 measured on a plane 0.3mm above the bottom of the pocket. (A_0 与 B_0 在同一平面测量且距口袋底部0.3MM)
4. K_0 measured from a plane on the inside bottom of the pocket to the top surface of the carrier.
(K_0 为口袋底部与材料表面的平面距离。)
5. All dimensions meet EIA-481-D requirements.
(所有尺寸符合EIA-481-D标准要求。)
6. Material: Black polystyrene
(材料:黑色聚苯乙烯。)
7. Thickness: $0.3 \pm 0.05 \text{ mm}$.
(厚度: 0.3 ± 0.05 毫米。)
8. Packing length per 22" reel : 200 Meters.
(每个22"卷轴包装长度为 200米。)
9. Component loader per 13" reel : pcs.
(每个13"卷轴可装个零件。前后各空 PCS)

注：未注明公差为 ± 0.1 ；
F值以 B_0 为中心；
P2值以 A_0 为中心。

SC8450/SC8460 series



Up to 150A, High Accuracy Current Sensor with Adjustable Over Current Fault Detection Current Sensor IC

Important Notice

SENK SEMI. co., Ltd. Reserves the right to make, from time to time, such departures from the detail specifications as may be required to permit improvements in the performance, reliability, or manufacturability of its products. Before placing an order, the user is cautioned to verify that the information being relied upon is current.

SENK SEMI.'s products are not to be used in life support devices or systems, if a failure of an SENK SEMI.. Product can reasonably be expected to cause the failure of that life support device or system, or to affect the safety or effectiveness of that device or system.

The information included herein is believed to be accurate and reliable. However, SENK SEMI. Co., Ltd. Assumes no responsibility for its use; nor for any infringement of patents or other rights of third parties which may result from its use.

Revision History

Revision	Change	Page	Author	Date
1.0	Initial draft	1-25	LEC	2024.04.03
2.0	Add SC8450A1FT-150F3、SC8460A1FT-150F5	2	MWJ	2024.07.03